

Universal Serial Bus Implementers Forum Full and Low Speed Compliance Test Procedure

Revision 1.0rc2

January 12, 2001

**For Review and Discussion Only
Draft Document Subject to Revision or Rejection
Not For Publication or General Distribution**

Revision History

Rev	Date	Filename	Comments
1.0rc2	12-JAN-2001	USBIF-TestProc1rc2.DOC	add www.usb.org Compliance Page URL
1.0rc1	10-DEC-2000	USBIF-TestProc1rc1.DOC	incorporate latest comments
0.9	15-MAY-2000	USBIF-TestProc09.DOC	release for public review
0.9rc1	14-MAY-2000	USBIF-TestProc09rc1.DOC	incorporate latest comments
0.9rc	1-MAY-2000	USBIF-TestProc09rc.DOC	incorporate comments following March Plugfest
0.7f	27-MAR-2000	USBIF-TestProc07f.DOC	incorporate comments from Kosta Koeman
0.7e	10-MAR-2000	USBIF-TestProc07e.DOC	simplify icons in drawings to save space
0.7d	9-MAR-2000	USBIF-TestProc07d.DOC	add drawings and section details
0.7c	4-MAR-2000	USBIF-TestProc07c.DOC	incorporate comments & section details
0.7b	27-FEB-2000	USBIF-TestProc07b.DOC	continue to add section details
0.7a	26-FEB-2000	USBIF-TestProc07a.DOC	add figures and section details
0.7	20-FEB-2000	USBIF-TestProc07.DOC	Initial draft

Please send comments via electronic mail to techsupp@usb.org

USB-IF Full and Low Speed Compliance Test Procedure
© Copyright 2001, USB Implementers Forum, Inc.
All rights reserved.

<p>For Review and Discussion Only Draft Document Subject to Revision or Rejection Not For Publication or General Distribution</p>

DISCLAIMER OF WARRANTIES

THIS SPECIFICATION IS PROVIDED "AS IS" AND WITH NO WARRANTIES OF ANY KIND, EXPRESS OR IMPLIED, INCLUDING, WITHOUT LIMITATION, NO WARRANTY OF NONINFRINGEMENT, NO WARRANTY OF MERCHANTABILITY, NO WARRANTY OF FITNESS FOR A PARTICULAR PURPOSE, NO WARRANTY OF TITLE, AND NO WARRANTY ARISING OUT OF ANY PROPOSAL, SPECIFICATION, OR SAMPLE, ALL OF WHICH WARRANTIES ARE EXPRESSLY DISCLAIMED.

WITHOUT LIMITING THE GENERALITY OF THE FOREGOING, USB-IF AND THE AUTHORS OF THE SPECIFICATION DO NOT WARRANT OR REPRESENT THAT USE OF THE SPECIFICATION WILL NOT INFRINGE THE INTELLECTUAL PROPERTY RIGHTS OF OTHERS. USERS OF THE SPECIFICATION ASSUME ALL RISK OF SUCH INFRINGEMENT, AND AGREE THAT THEY WILL MAKE NO CLAIM AGAINST USB-IF OR THE AUTHORS IN THE EVENT OF CLAIMS OF INFRINGEMENT.

USB-IF IS NOT LIABLE FOR ANY CONSEQUENTIAL, SPECIAL OR OTHER DAMAGES ARISING OUT OF THE USE OF THE SPECIFICATION.

LICENSE FOR INTERNAL USE ONLY

USB-IF HEREBY GRANTS A LICENSE TO REPRODUCE AND TO DISTRIBUTE THIS SPECIFICATION FOR INTERNAL USE ONLY. NO OTHER LICENSE, EXPRESS OR IMPLIED, BY ESTOPPEL OR OTHERWISE, IS GRANTED HERewith, AND NO LICENSE OF INTELLECTUAL PROPERTY RIGHTS IS GRANTED HERewith.

All product names are trademarks, registered trademarks, or servicemarks of their respective owners.

Table of Contents

Introduction	vii
Purpose	vii
Scope.....	vii
A Test Procedure Scenarios – All tests	A-1
A.1 Identify System, Hub, or Peripheral as Unit Under Test.....	A-1
A.2 Required Tests.....	A-2
A.2.1 Add-in Cards, Motherboards, and Systems.....	A-2
A.2.2 Hubs.....	A-2
A.2.3 Full Speed Peripherals.....	A-2
A.2.4 Low Speed Peripherals.....	A-2
B Electrical Tests	B-1
B.1 Required Equipment and Equipment Setup	B-1
B.1.1 'Special' items (test fixtures) to be acquired through USB-IF, Inc.	B-1
B.1.2 standard test equipment	B-3
B.1.3 standard/available USB products.....	B-3
B.1.4 General Equipment Setup.....	B-3
B.2 Host or Hub Power Provider (Droop/Drop) Testing	B-12
B.2.1 Equipment Used.....	B-12
B.2.2 Drop Testing.....	B-12
B.2.3 Droop Testing.....	B-15
B.2.4 Reporting Results.....	B-18
B.3 Host Downstream Signal Quality Testing	B-19
B.3.1 Equipment Used.....	B-19
B.3.2 Equipment Setup for testing Downstream Traffic	B-19
B.3.3 Signal Integrity Test - Downstream Signal test.....	B-19
B.3.4 Reporting Results.....	B-23
B.4 Inrush Current Testing	B-24
B.4.1 Equipment Used.....	B-24
B.4.2 Equipment Setup.....	B-25
B.4.3 Test Steps	B-25
B.4.4 Reporting Results.....	B-26
B.5 Hub Downstream Signal Quality Testing	B-27
B.5.1 Equipment Used.....	B-27
B.5.2 Equipment Setup for testing Downstream Traffic	B-27
B.5.3 Signal Integrity Test - Downstream Signal test.....	B-27
B.5.4 Reporting Results.....	B-31
B.6 Upstream Signal Quality Testing	B-32
B.6.1 Equipment Used.....	B-32

For Review and Discussion Only
Draft Document Subject to Revision or Rejection
Not For Publication or General Distribution

B.6.2	Equipment Setup.....	B-32
B.6.3	Test Steps	B-33
B.6.4	Reporting Results.....	B-34
C	Device Framework Testing	C-1
C.1	Equipment Used.....	C-1
C.2	Equipment Setup.....	C-1
C.2.1	Prepare the Host System.....	C-1
C.3	Test Steps	C-2
C.3.1	All Devices	C-2
C.3.2	Non-Hub Devices	C-2
C.3.3	Small Hubs (4 Ports or Less)	C-3
C.3.4	Large (Self-Powered) Hubs (More than 4 Ports)	C-4
C.3.5	Hubs with Embedded Devices	C-5
C.4	Reporting Results.....	C-6
D	Windows 2000 Peripheral Interoperability Testing.....	D-1
D.1	Equipment Used.....	D-1
D.2	Equipment Setup.....	D-2
D.2.1	Prepare the Host System.....	D-2
D.2.2	Initialize the Gold Tree	D-3
D.3	Test Steps	D-4
D.3.1	Non-Hub Devices	D-4
D.3.2	Hubs.....	D-11
D.3.3	Measuring Average Current Draw	D-22
D.4	Reporting Results.....	D-24
D.4.1	Interoperability Results	D-24
D.4.2	Current Measurement Results	D-26
E	Windows 98SE Peripheral Interoperability Testing.....	E-27
E.1	Equipment Used.....	E-27
E.2	Equipment Setup.....	E-28
E.2.1	Prepare the Host System.....	E-28
E.2.2	Initialize the Gold Tree	E-29
E.3	Test Steps	E-30
E.3.1	Non-Hub Devices	E-30
E.3.2	Hubs.....	E-37
E.3.3	Measuring Average Current Draw	E-48
E.4	Reporting Results.....	E-50
E.4.1	Interoperability Results	E-50
E.4.2	Current Measurement Results	E-52
F	Windows 98SE Host Interoperability Testing	F-1
F.1	Equipment Used.....	F-1
F.2	Prepare the Host System.....	F-1

F.3 Test Steps F-3

G Windows 2000 Host Interoperability TestingG-1

G.1 Equipment Used.....G-1

G.2 Prepare the Host System.....G-1

G.3 Test StepsG-2

**For Review and Discussion Only
Draft Document Subject to Revision or Rejection
Not For Publication or General Distribution**

Introduction

The USB-IF Full and Low Speed Compliance Test Procedure is developed by the USB 2.0 Compliance Committee under the direction of USB-IF, Inc. In addition to other requirements, products must pass the compliance test procedure defined in this document in order to be posted on the USB-IF Integrators List and use the USB-IF logo in conjunction with the said product (if the vendor has signed the USB-IF Trademark License Agreement).

Purpose

The USB-IF Full and Low Speed Compliance Test Procedure documents a series of tests used to evaluate USB peripherals and systems operating at full speed and/or low speed. These tests are also used to evaluate the full and low speed operation of USB silicon that has been incorporated in ready-to-ship products, reference designs, proofs of concept and one of a kind prototypes of peripherals, add-in cards, motherboards, or systems.

Scope

The procedures documented here address the compliance of the three groups listed by applying the test procedures identified with each group:

- Add-in cards, motherboards, and systems
 - Power Provider (Droop/Drop) testing
 - Downstream Signal Quality
 - Interoperability
- Full speed and low speed hubs (no high speed support)
 - Power Provider (Droop/Drop) testing
 - Downstream Signal Quality
 - Upstream Signal Quality
 - Device Framework Testing (Chapter 9 and Chapter 11 compliance)
 - Interoperability
 - Average Current Consumption
- Full speed or low speed peripherals.
 - Upstream Signal Quality
 - Device Framework Testing (Chapter 9 compliance)
 - Interoperability
 - Average Current Consumption

Each test scenario shows the specific list of equipment used in the procedure, the initial equipment setup required, the individual steps used to run the procedure (including any equipment reset that is required between devices), and how the results are reported.

A Test Procedure Scenarios – All tests

A.1 Identify System, Hub, or Peripheral as Unit Under Test

Collect the following information before running any tests for later reporting.

1. Device: name of the unit under test
2. Device Description: describe the unit under test
3. Test Suite: identify the test suite or test station – this identification shall uniquely identify the equipment used for the testing should results need to be reproduced.
4. Date Tested: range of testing dates
5. Test Type: system or hub or peripheral
6. Device Category: system or hub or peripheral
 - a) System – no further items
 - b) Hub
 - a. Device Design: no microcontroller (i.e. silicon), microcontroller with USB drivers on same chip, or microcontroller with USB drivers on different chip
 - b. Power: bus-powered, self-powered, or both
 - c. USB connection: captive cable or standard cable with A and B plugs
 - d. Drivers: shall test with those provided by operating system
 - c) Peripheral
 - a. Device Design: no microcontroller (i.e. silicon), microcontroller with USB drivers on same chip, or microcontroller with USB drivers on different chip
 - b. Power: bus-powered, self-powered, or both
 - c. Drivers (source of drivers): device vendor, operating system, or third party
 - d. USB connection: captive cable or standard cable with A and B plugs
 - e. Speed: Full-speed or Low-speed
7. Test Suite Passed: this is determined after all appropriate test have been run

A.2 Required Tests

Compliance testing requires that the unit under test pass all test procedures listed for its category.

A.2.1 Add-in Cards, Motherboards, and Systems

- B.2 Host or Hub Power Provider (Droop/Drop) Testing
- B.3 Host Downstream Signal Quality Testing
- One or more Host Interoperability Testing procedures. These test procedures are operating system specific – a host may be submitted for testing with multiple operating systems; passing any host interoperability test procedure is sufficient for this portion of compliance testing.

A.2.2 Hubs

- B.4 Inrush Current Testing
- B.6 Upstream Signal Quality Testing
- B.2 Host or Hub Power Provider (Droop/Drop) Testing
- B.5 Hub Downstream Signal Quality Testing
- C Device Framework Testing
- One or more Device Interoperability Testing procedures. These test procedures are operating system specific – a hub may be submitted for testing with multiple operating systems; failing any interoperability test procedure causes the hub to fail compliance testing.

A.2.3 Full Speed Peripherals

- B.4 Inrush Current Testing
- B.6 Upstream Signal Quality Testing
- C Device Framework Testing
- One or more Device Interoperability Testing procedures. These test procedures are operating system specific – a device may be submitted for testing with multiple operating systems; passing any interoperability test procedure is sufficient for this portion of compliance testing.

A.2.4 Low Speed Peripherals

- B.4 Inrush Current Testing
- B.6 Upstream Signal Quality Testing
- C Device Framework Testing

- One or more Device Interoperability Testing procedures. These test procedures are operating system specific – a device may be submitted for testing with multiple operating systems; passing any interoperability test procedure is sufficient for this portion of compliance testing.

B Electrical Tests

B.1 Required Equipment and Equipment Setup

The following items are used.

Note that the equipment listed, the test procedure steps, and the actual list of required tests is expected to change. Please refer to <http://www.usb.org/developers/complian.html> on the USB-IF, Inc. web site for the latest version of this document.

B.1.1 'Special' items (test fixtures) to be acquired through USB-IF, Inc.

item	description/model	qty
100mA Load Board		1
500mA Load Board		1*
Droop Test Board		1
Droop Test Loop-Back Cable		1
SQiDD Board	Signal Quality and Droop/Drop test jig	1
Intel Customer HUB (CHUB)		5**
Phihong 5V 4A power Supply (for CHUBs)		5**

** a 6th unit is recommended as a spare

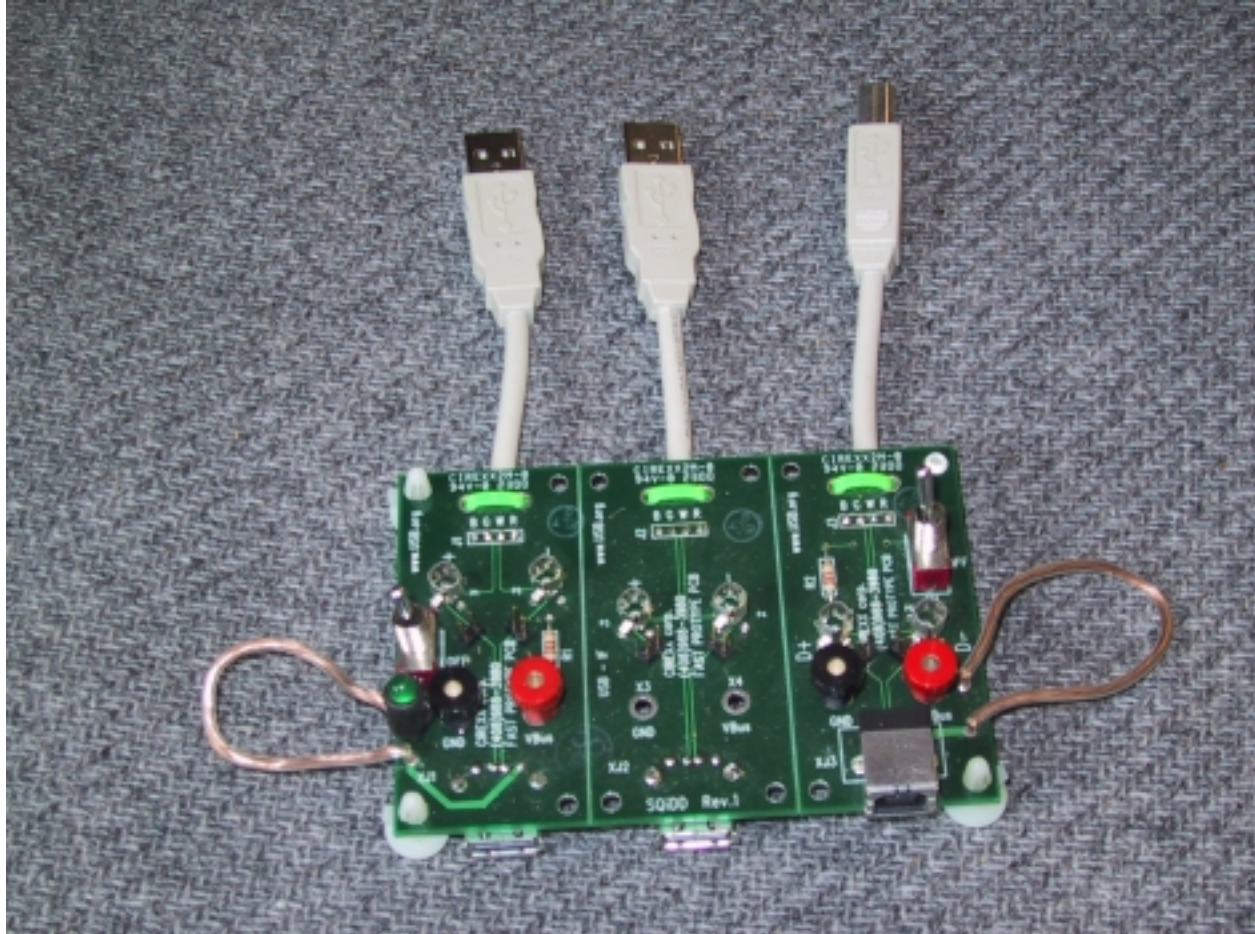

Figure B-1: SQiDD Board

The Signal Quality Droop Drop or SQiDD board is divided into three sections; Section 1 has AA signal and power break monitor points together with an Inrush Current switch and V_{BUS} current monitor loop. Section 2 only has AA signal and power break monitor points. Section 3 has BB signal and power break monitor points together with an Inrush Current switch and V_{BUS} current monitor loop.

All three sections of the SQiDD board are used for signal quality testing and support multiple Oscilloscope probe types. The Tektronix P6204/5 Oscilloscope probe types are obsolete. These probes are only suitable for low- and full-speed signal quality testing. A header for a newer type probe is used as the default Signal Quality Probe point. This header supports new type probes like the Tektronix P6243 and P6245 probes which offer limited ability to probe high-speed (USB 2.0) signaling environments.

Two sections, 1- AA and 3- BB, of the SQiDD board are also used for Inrush and Power Testing with wire loops that are used with Clamp on type current probes. Added power switch functions support Inrush testing on these two sections. A three-position switch has a normal powered mode as its default which passes V_{BUS} straight through. Switch position 2 shorts out and discharges the V_{BUS} and Ground rails of the Device Under Test (DUT) or Hub Under Test (HUT) through a 1 K Ω resistor. Switch position 3 opens the V_{BUS} line and allows for hooking up the DUT or HUT and current probe.

B.1.2 standard test equipment

item	description/model	qty
oscilloscope	Tektronix TDS 684C or 784C *	1
TDS Probes	P6243 voltage probes	3
Current Probe	TCP202 current probe	1
multimeter	Keithley 2000 Multimeter	1
CATC UHT (hub tester)	firmware 1.6 or later	2
USB Host System with GPIB board	Hardware Configuration: TBD National Instruments I-488.2 GPIB support for connection to 'oscilloscope'	1

* supported by available MatLab scripts – other models may require extensive script modifications

**use 'USB Host System with GPIB board' for all test scenarios

B.1.3 standard/available USB products

item	description/model	qty
Intel Create and Share USB Camera	P/N 735147-001, Model#: CS330	1
mouse	Logitech mouse P/N 830311-1000, Model#: M-BB48	8
one meter USB cables	any listed on USB-IF Cables and Connectors Integrators List	3
five meter USB cables	any listed on USB-IF Cables and Connectors Integrators List	6

B.1.4 General Equipment Setup

B.1.4.1 Oscilloscope

The following section defines the test equipment setup and operational requirements. Refer to the equipment list items for setting up equipment. Follow the step-by-step instructions to set up the oscilloscope setups for Signal Quality testing.

Scopes from various manufacturers are capable of the required test operation. However, the currently available MatLab scripts support the Tektronix model TDS 684C and 784C oscilloscope. Using other models may require extensive script modifications.

Each setup command that starts with one of the main buttons on the scope's front panel is marked with a bullet, with subsequent selections being made on the horizontal and vertical rows of buttons next to the scope's display. If multiple selections in a row are made from one main menu, the subsequent selections are indented below the bulleted one according to how far down they are in the submenus. For some selections, you'll need to scroll through the menu at the right side of the scope's display to find them.

Depending on the model of TDS, the exact horizontal division settings, record lengths, and trigger positions may vary. If a wrong initialization step taken, the test operator can start over from the last point at which a setup was saved by recalling that setup: setup→recall setup→setup n .

These setup steps may need some customization for a given measurement:

- Depending on the amount of data returned or sent on the bus, the signal integrity setups may need adjustments to trigger positioning, record length, and the horizontal division size. Try to keep the horizontal division size @ 50 points/division close to 200ns/division for LS signals and 25 or 50ns/division for FS.
- The inrush setups will need a lot of adjustment, as inrush currents manifest a wide variety of durations and peak currents. Expect to use vertical division settings anywhere from 100mA/division to 5A/division and timebases between 500ns/div and 20 μ s/division. If you need a timebase longer than 20 μ s/division, it's usually best to max out the scope's record length before upping the timebase.

The oscilloscope is used as the front-end capture of data that is transferred to the PC to be further analyzed, documented and saved in soft data format. This process uses the National Instruments GPIB board to transfer instrumentation data from the oscilloscope to the PC. Data point analysis is done with MatLab analysis software using specific MatLab scripts. The GPIB board and its associated software is installed in the PC.

All of the setups split the oscilloscope's trace display into two areas. The upper one is a zoom window that shows the contents of the box shown in the lower window. The lower window shows the entire contents of the oscilloscope's records (except for 15k point records, where it only shows two thirds of the record at any given time for reasons known only to Tektronix). This setup is handy for looking at any individual part of the captured waveform. You can move the box around with the horizontal and vertical position knobs as long as the upper graticule is active (it's selected with zoom→graticule→upper), though it's usually more convenient to do one's zooming in MatLab. If you need to work with the lower graticule, select it (zoom→graticule→lower), and do whatever it is that needs to be done.

In addition, all of the setups use gated, paired cursors. The paired bit means the scope puts markers on the currently selected channel where it crosses the cursors and gives you X and Y deltas between the markers. This comes in handy occasionally. The gated bit means that the measurements the oscilloscope (rise/fall time, mean, max, *etc.*) makes are done on the part of the record between the two cursors. This lets you gate out a particular part of the record that's interesting and take measurements for just that part of the record, rather than having the scope indiscriminately apply the measurements to the entire record. Generally, though, it's faster and more convenient to look at the eye diagram in MatLab or zoom in on MatLab's plot of the scope data.

B.1.4.1.1 Tips on Using the Scope

- Pressing shift activates *Coarse Knobs*, which increases the effect of anything you twirl. This is really handy for moving cursors and the zoom window around. Pressing shift again will turn coarse knobs off.
- The "I" shaped bar above the upper graticule represents the entire contents of the oscilloscope's records. The brackets indicate the area of the record is displayed in the lower graticule. The T marks

the trigger point's position in the record, and the dashed and solid lines mark the positions of the inactive and selected cursors, respectively.

B.1.4.1.2 Initial Scope Setup

Note: step 2 requires a minimum one hour for scope warm up before completing the initial scope setup procedure.

1. Refer to the instrument's user guide for initial probe compensation settings.
2. Allow one-hour warm up of Scope
3. Run Signal Path Compensation (SPC). SPC corrects for DC inaccuracies caused by temperature variations and/or long-term drift. SPC can be any time after the scope is warmed up and should be run whenever the scope's ambient temperature has changed by more than 5 degrees C. (Ensure that the scope has been powered on for an hour prior to running signal path compensation. Running signal path compensation before the scope is warmed up **will** result in erroneous test results.)
 - ensure probes are disconnected
 - utility→system→cal→OK compensate signal paths

Signal path compensation will take about 10 minutes.

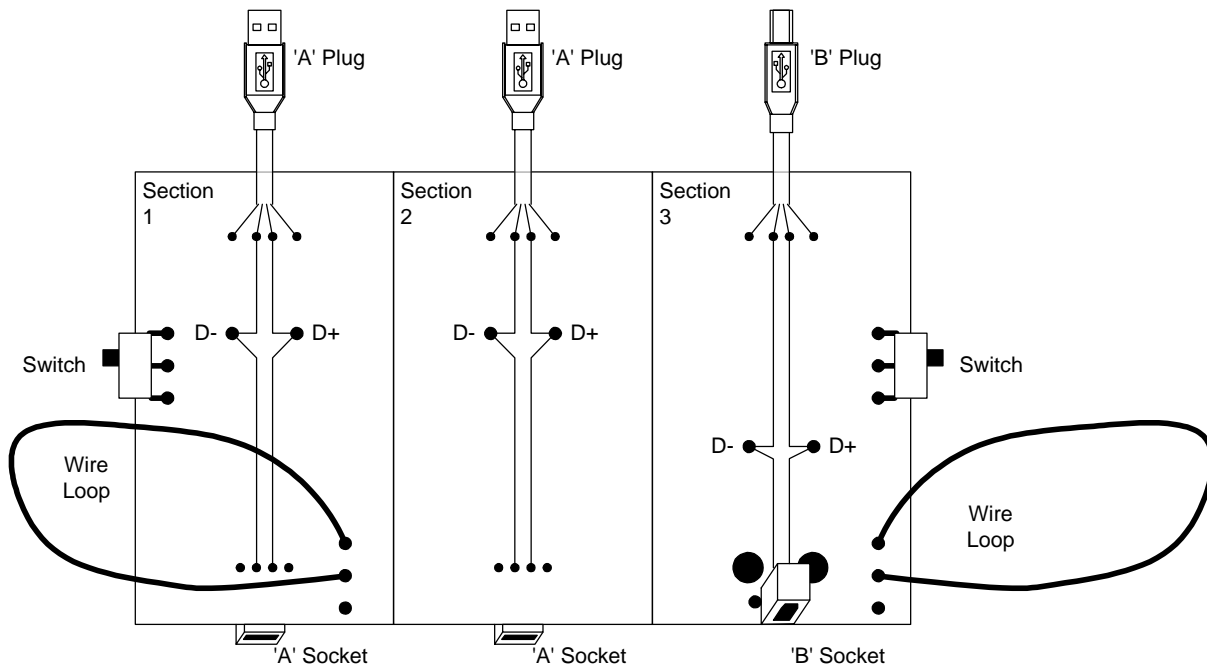

Figure B-2: SQiDD Board

4. Attach oscilloscope probes to the SQiDD Board as shown:
 - ch 1: voltage probe→SQiDD Board section 1 or section 3 D-
 - ch 2: voltage probe→SQiDD Board section 1 or section 3 D+
 - ch 3: voltage probe→ SQiDD Board section 2 (D- for LS signals, D+ for FS signals)
 - ch 4: current probe→SQiDD Board wire loop on section 1 or section 3
5. Reset scope to factory defaults
 - setup→recall factory setup→OK confirm factory init

Note: The following setups are done in sequential order one time and saved for one-button recall during actual testing. These setups can also be saved to Floppy Disk on various scopes for later use.
6. Set GPIB address
 - utility→system→I/O→configure talk./listen→talk./listen address→1

B.1.4.1.3 Upstream LS Signal Integrity Setup

1. Define LS upstream trigger

Note that the setup described in the preceding section is a prerequisite for this setup.

- probes connected to scope channels 1 through 4 as described in section B.1.4.1.2 step 2
- acquire menu→repetitive signal→off
(this is not an option on all scopes)
- trigger menu→type→logic

```

class→pattern
define inputs → ch1          low
                  ch2          low
                  ch3          high
                  ch4          don't care

define logic→AND
trigger when→true for more than 100ns
set thresholds → ch1          .8V
                  ch2          .8V
  
```

ch3 2.7V
mode and hold off→normal

2. Setup LS upstream display

- horizontal menu

trigger position→75%
record length→fit to screen on
record length→5000 points (in 10 divs)
horizontal scale→main scale @ 50pts/div→200ns

- zoom→mode→preview
- vertical menu→ch1→1V/div
- vertical menu→vertical position→-1.5div
- vertical menu→ch2→1V/div

vertical position→-1.5div

3. Setup rise/fall time measurements

- ch1
- measure→select measurement for ch1→rise time

fall time

- ch2

rise time
fall time
gating→gate with v bar cursors

- cursor→function→paired

4. Save LS upstream setup

- setup→save current setup→to setup 1

B.1.4.1.4 Upstream FS Signal Integrity Setup

Note that the setup described in the preceding section is a prerequisite for this setup.

1. setup FS upstream display
 - horizontal menu→trigger position→68%
horizontal scale→main scale @ 50pts/div→20ns
2. save FS upstream setup
 - setup→save current setup→to setup 2

B.1.4.1.5 Downstream LS Setup

Note that the setup described in the preceding section is a prerequisite for this setup.

1. Setup downstream LS trigger
 - trigger menu→type→edge
source→ch2
level→1.65V
 - horizontal menu→trigger position→6%
record length→2500 points (in 10 divs)
horizontal scale→main scale @ 50pts/div→500ns
2. Save downstream LS setup
 - setup→save current setup→to setup 3
Note: Downstream setups can use positive or negative edges.

B.1.4.1.6 Downstream FS Setup

1. Setup downstream FS trigger
 - trigger menu→type→edge
source→ch2
level→1.65V

- horizontal menu→trigger position→40%
record length→5000 points (in 10 divs)
- horizontal scale→main scale @ 50pts/div→40ns

2. Save downstream FS setup

- setup→save current setup→to setup 4

B.1.4.1.7 Inrush Testing Setup

3. Setup for Inrush current testing

- ch1 waveform off
- ch2 waveform off
- press ch4 button (turn on channel 4 waveform)
- vertical menu → position → -3div
- horizontal menu → trigger position → 10% record length → 15000points
- record length→15000 points (in 15 divs)
- horizontal scale → main scale → 50pts/div →10ms
- trigger menu → source → ch 4
- level → 10mV
- measure → select measurement for ch4 → max

If using a P6302 current probe

- verify that the vertical scale shows A /div or mA/div
- vertical menu → fine scale → 10mA/div
- set current probe to 1A/div

Save inrush current setup:

- setup → save current setup → to setup 5

B.1.4.2 Test System Software Setup

B.1.4.2.1 Prepare the Host System

The host software required is Windows 2000 Professional, the USB-IF USBCheck tool, GPIB Data Acquisition software, and MatLab analysis software. Either restore the saved image of the previously prepared system or follow the steps given in the following sections.

B.1.4.2.2 Install Windows 2000 Professional

Use the default installation options: select 'typical' system configuration, install 'most common components', and select location 'US'.

Install any required platform-specific drivers – all devices should be 'working properly'; there should be no 'unknown devices' shown in the Windows 2000 Device Manager.

B.1.4.2.3 Install USBCheck

Run the USBComp.exe installation package from USB-IF, Inc. to install the USBCheck-related tools.

B.1.4.2.4 Install and Configure MatLab

Install GPIB Data Acquisition program (DAQ) and MatLab Software using default options. Copy the USB-IF supplied MatLab scripts to the MatLab working directory.

1. Launch MatLab
2. Check Initial Setup
 - GPIB DAQ or data acquisition program setup.
 - MatLab scripts installed and have directory structure: Contents of toolbox can be viewed by typing "help \$directory" at MatLab's prompt, or view the documentation of individual scripts by typing "help \$scriptName".
 - The individual scripts' documentation covers each script's arguments and expected data format in detail. In the example above, you'd view the toolbox contents by typing "help usbfun". The documentation for the main testing scripts can be accessed via "help usbinrushcheck" and "help usbsigcheck".

MatLab Scripts

Current Inrush Analysis

```
Usbinrushcheck -- Check USB inrush currents
```

Signal Integrity Analysis

Usbsigcheck -- Check driven USB signals and receivers

AlignPoints.m --Align eye diagram pivots to data

Crossover.m -- Extract crossover voltages and times

Datarate.m -- Extract data rate

eyediag.m -- Find eye violations and plot eye

findSEedges.m -- Locate single ended edges

pointsError.m -- Support function for alignpoints

B.2 Host or Hub Power Provider (Droop/Drop) Testing

B.2.1 Equipment Used

Note that the equipment listed, the test procedure steps, and the actual list of required tests is expected to change. Please refer to <http://www.usb.org/developers/complian.html> on the USB-IF, Inc. web site for the latest version of this document.

qty	item
1	USB Host System with GPIB board
1	GHOST image for "electrical" Testing
1	oscilloscope
1	multimeter
1	100mA Load Board
1	500mA Load Board (additional board(s) if testing Hub with more than 7 ports)
1	Droop Test Board
1	*Droop Test Loop-Back Cable
1	one meter USB cables

*Current Droop Board uses a standard 1 meter USB cable to replicate electrical characteristics of an actual USB device/cable combination

B.2.2 Drop Testing

B.2.2.1 Equipment Setup

Setup Voltmeter to measure voltage Drop across each load board.

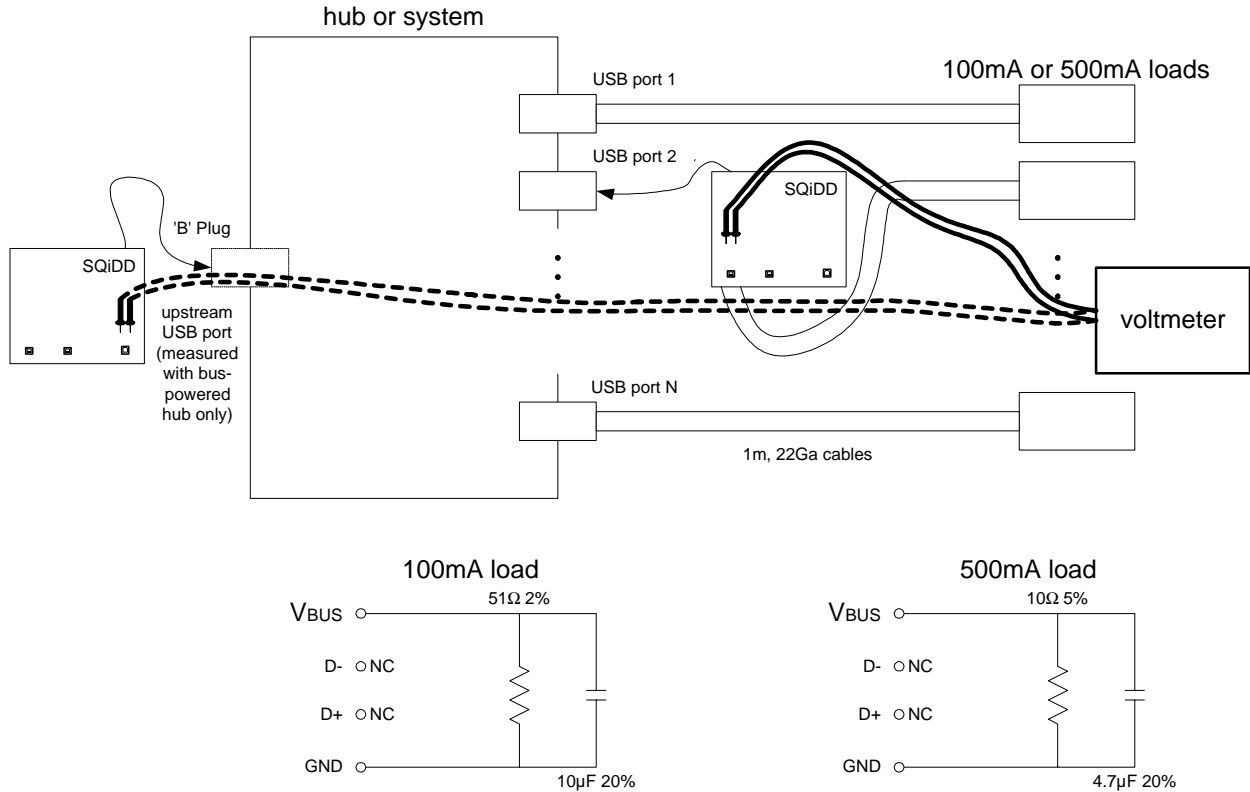

Figure B-3: Drop Test Setup

B.2.2.2 Test Steps

Note: Hubs that operate in both self-powered and bus-powered modes shall be tested in both modes.

B.2.2.2.1 Self-Powered Hubs

1. Plug in 500mA load board into ports one at a time and observe voltage is between 4.75 and 5.25V.
2. Repeat as necessary for all ports on HUB.

$$V_{DROD} \equiv V_{NL} - V_{LOADED}$$

Where

$$V_{NL} \equiv V_{BUS} \text{ at a downstream USB connector with USB ports open circuited (no load)}$$

And

$$V_{LOADED} \equiv V_{BUS} \text{ at a downstream USB connector with 100 or 500mA loads, as appropriate, on all USB ports}$$

**For Review and Discussion Only
 Draft Document Subject to Revision or Rejection
 Not For Publication or General Distribution**

B.2.2.2.2 Bus-Powered Hubs

1. Plug in 100mA load board into ports one at a time and observe voltage is greater than 4.40 V.
2. Repeat as necessary for all ports on HUB.

$$V_{\text{DROP}} \equiv V_{\text{UPSTREAM}} - V_{\text{DOWNSTREAM}}$$

$$V_{\text{UPSTREAM}} \equiv V_{\text{BUS}} \text{ at hub's upstream connection}$$

$$V_{\text{DOWNSTREAM}} \equiv V_{\text{BUS}} \text{ at one of the hub's downstream ports}$$

B.2.2.3 Test Criteria

Section 7.2.2 of the USB 1.1 specification requires powered USB ports to provide a V_{BUS} between 4.75 and 5.25V while bus-powered hubs must maintain V_{BUS} at 4.40V or greater. Drop testing evaluates V_{BUS} under both no-load and full-load (100 or 500mA, as appropriate) conditions.

Self-powered hubs, systems, and laptops must provide a voltage between 4.75 and 5.25V under all load conditions.

Bus-powered hubs must have a $V_{\text{DROP}} \leq 100\text{mV}$ between their upstream and downstream ports when 100mA loads are present on all downstream ports. This ensures that they will supply 4.4V to a downstream device, given a 4.75V upstream supply, minus 100mV drop through the hub and 250 mV drop through the upstream cable. If the hub does not use a captive cable (the USB cable has a B plug), the voltage drop is the difference between the measured upstream voltage level and the lowest measured downstream value. Bus-powered hubs with captive cables (the USB cable does not have a B plug) must have $V_{\text{DROP}} \leq 350\text{mV}$ between the upstream connector and their downstream ports; this includes the drop through the cable.

Special consideration will be made for laptops which are unable to provide compliant voltages with 500mA loads while running off of battery power, provided they can meet the required voltages with one or more of the loads reduced to 100mA. However, the end user may experience confusion and difficulty in this situation, unless the operating system or laptop vendor provide a warning message window alerting the user that a high power device can not be used under battery power.

B.2.3 Droop Testing

B.2.3.1 Equipment Setup

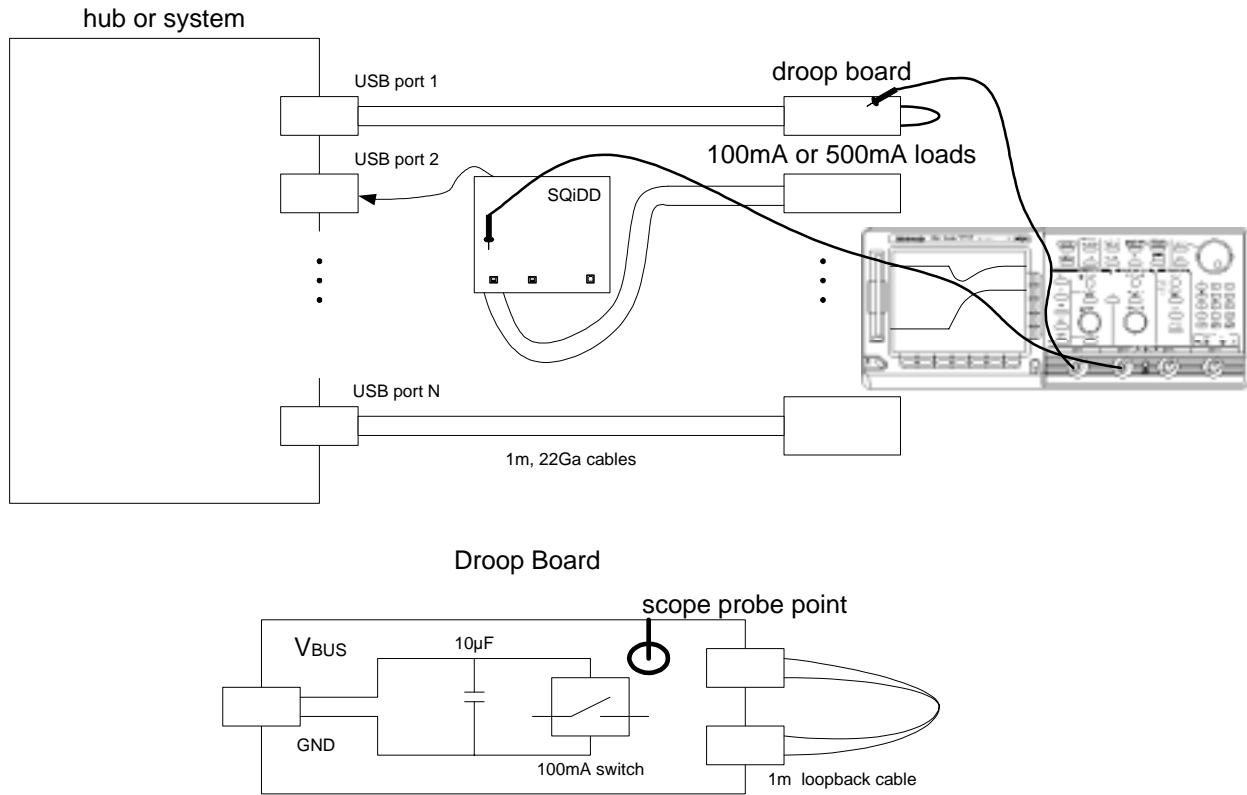

Figure B-4: Droop Test Setup

Follow the Step by step instructions to set up the oscilloscope setups for Signal Quality testing. Currently this testing uses a Tektronix oscilloscope preferably a model TDS 684C or 784C.

B.2.3.2 Test Steps

CAUTION:

To protect the Droop Relay, the Droop Board must be powered on last and powered off first.

1. Setup Oscilloscope Channel 1 to 1V/div and Channel 2 to 2V/div

Timebase set for 25 us/div

Set the Oscilloscope Voltage Reference to V_{BUS} level less 330mV

acquire menu → average [16]

2. Connect the Oscilloscope as follows:

Channel 1 is connected to the Droop Board switch to monitor the switch pulse

Channel 2 is connected to each V_{BUS} line on load board port

3. Observe Droop voltage on each port of the HUB

For all devices:

$V_{DROOP} \equiv$ the difference between V_{BUS} when the 100mA switch is open and the lowest observed V_{BUS} after the switch closes

B.2.3.3 Test Criteria

Section 7.2.4.1 of the USB 1.1 specification allows a maximum droop of 330mV in the V_{BUS} supplied to a USB port when a device is hot plugged into another port. Droop testing evaluates worst-case droop by applying a 100mA load which switches on and off to one of the available ports when all other ports are supplying the maximum load possible. All V_{BUS} measurements are relative to local ground.

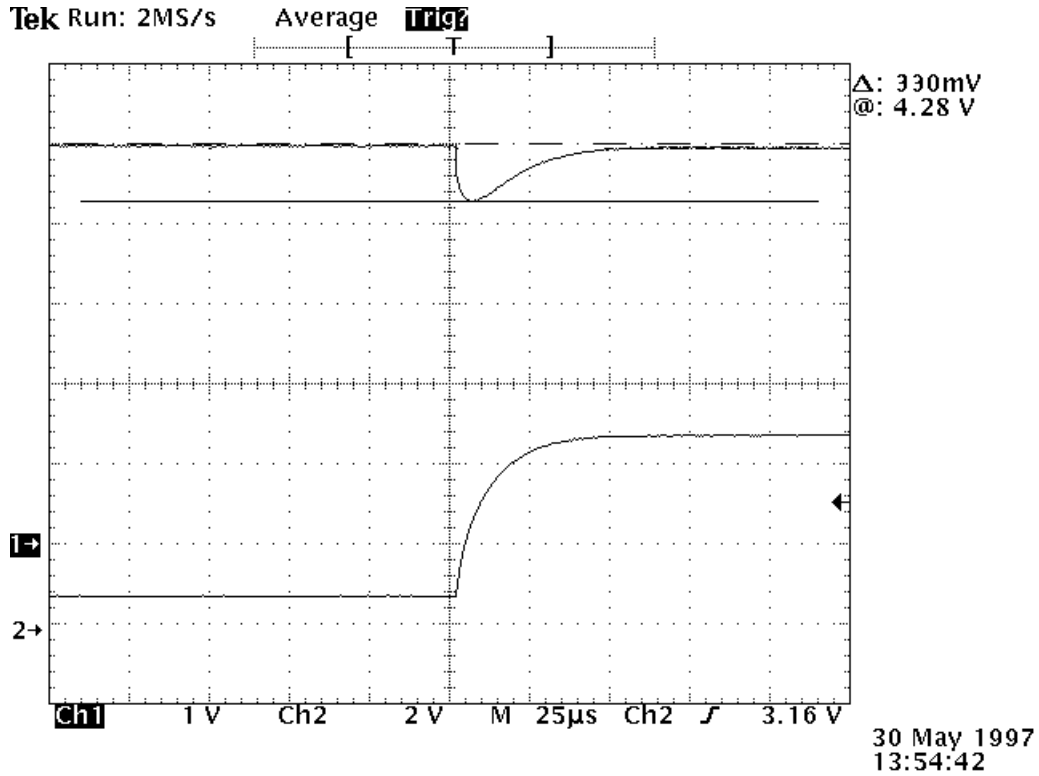

Figure B-5: Droop Measurement Example

The USB-IF will test—at the connectors—the sample provided for compliance to these requirements. It is the responsibility of the vendor to ensure all units produced satisfy the requirements of this test.

B.2.3.4 Test Results

	Bus-powered Hub	Self-powered Hub/System	Laptop	
			battery-powered	self-powered
load type	100mA	500mA	___ 100 ___ 500mA	500mA
V_{NL}				
V_{LOADED}				
$V_{UPSTREAM}$				
$V_{DOWNSTREAM}$				
V_{DROOP}				
V_{DROOP}	Less than 330mV			

For Review and Discussion Only
Draft Document Subject to Revision or Rejection
Not For Publication or General Distribution

B.2.4 Reporting Results

1. No Load Voltage: passing values are from 4.75 to 5.25 V
2. Loaded Voltage: passing values are from 4.75 to 5.25 V
3. Upstream Voltage: passing values are from 4.40 to 5.25 V
4. Downstream Voltage: passing values are from 4.75 to 5.25 V
5. Voltage Drop:
6. Droop Voltage:

B.3 Host Downstream Signal Quality Testing

B.3.1 Equipment Used

Note that the equipment listed, the test procedure steps, and the actual list of required tests is expected to change. Please refer to <http://www.usb.org/developers/complian.html> on the USB-IF, Inc. web site for the latest version of this document.

qty	item
1	System with GPIB support
1	GHOST image for "electrical" Testing
1	oscilloscope
2	TDS Probes
6	five meter USB cable
1	one meter USB cable
1	SQiDD board
5	Intel Customer HUB
5	Phihong 5V 4A power Supply (for CHUBs)
1	Intel Create and Share USB Camera (full speed test device)
1	mouse

B.3.2 Equipment Setup for testing Downstream Traffic

The best method to capture and analyze full-speed downstream signal quality is to trigger on either SOF packets or use a falling edge trigger on D+.

The best method to capture and analyze low-speed downstream signal quality is to capture both a keep-alive (low speed EOP) and a packet. The root hub is required to either generate a keep-alive or send low speed traffic once per frame whenever a low speed device is directly attached. To capture downstream traffic with low-speed devices a trigger on D- or an SE0 pattern trigger is used.

Two channels of the oscilloscope are used.

Setting up Testing of Downstream Traffic

B.3.3 Signal Integrity Test - Downstream Signal test

All root hubs (found on all host add-in cards, motherboards, and systems) produce downstream signals that can be tested.

B.3.3.1 Low-speed Downstream Signal Quality Test

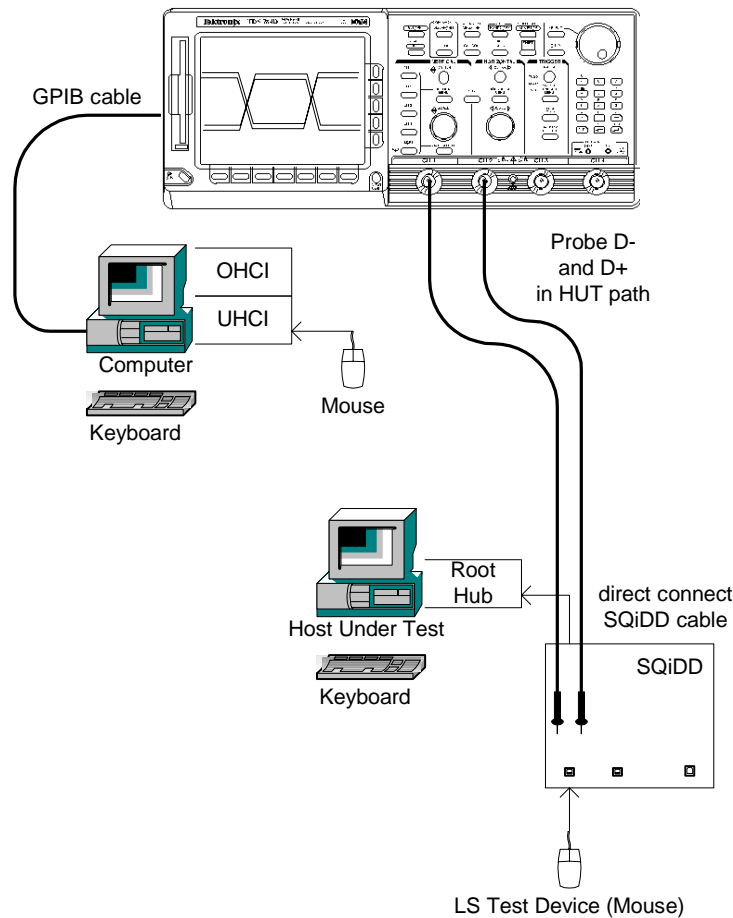

Figure B-6: Host LS Downstream Signal Quality Test

1. verify the scope is warmed up (running at least 1 hour)
ensure signal path compensation has been run on the scope recently (within 4 hours)
2. Start MatLab
3. Start GPIB DAQ
4. Get zeroes
(Scope must be triggering in order to get zeros (typically ranges between 50-150mV) and DUT must be unplugged)
5. Quit USBCheck
6. On Oscilloscope recall Setup for Low Speed downstream signal (Setup 3)
7. Connect scope channels 1 and 2 to SQiDD board section 1.

8. Connect SQiDD section 1 'A' plug to a down stream port on the Host Under Test (HUT).
9. Plug low speed device to 'A' socket on SQiDD board section 1
10. Low speed device enumerates and drivers are loaded
11. Check scope to make sure waveform has been captured
12. GPIB DAQ auto --> USB Downstream Signals --> no MatLab analysis
13. Save it as <USB-IF SN>.dl.tsv ; example: usbd123dl
14. If needed give the results in floppy.

B.3.3.2 Full-speed Downstream Signal Quality Test

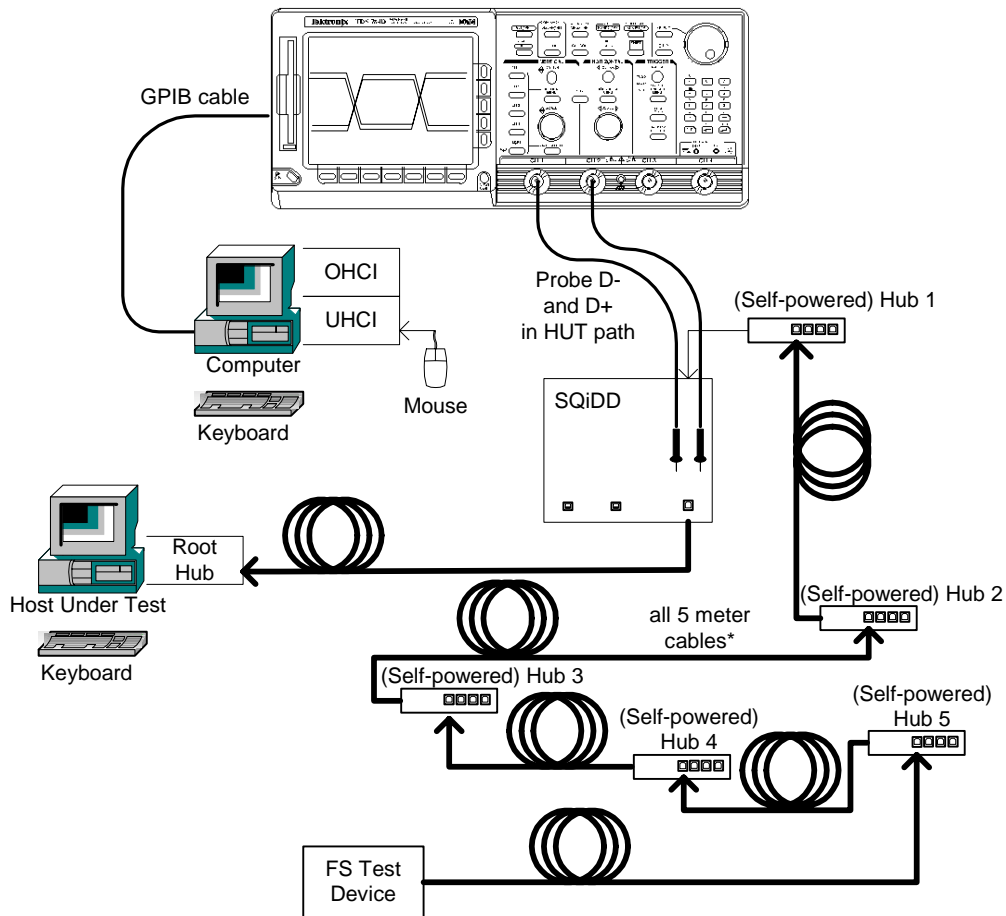

Figure B-7: Host FS Downstream Signal Quality Test

1. verify the scope is warmed up (running at least 1 hour)
ensure signal path compensation has been run on the scope recently (within 4 hours)
2. Start MatLab
3. Start GPIB DAQ
4. Get zeroes
Scope must be triggering in order to get zeroes (typically ranges between 50-150mV) and DUT must be unplugged.
5. Quit USBCheck
6. On Oscilloscope recall Setup for Full Speed downstream signal (Setup 4)
7. Connect scope channels 1 and 2 to SQiDD board section 3.

8. Plug 5 meter cable to one of the downstream ports on the Host Under Test (HUT).
9. Plug 5 meter cable into 'B' socket on SQiDD board section 3.
10. Enumerate hubs 1 through 5.
11. Start USBCheck
12. Plug Full Speed test device into hub 5 and enumerate device. (If device fails to enumerate, HUT fails possibly due to problem with receiver sensitivity.)
13. Check scope to make sure waveform has been captured
14. GPIB DAQ auto --> USB Downstream Signals --> no MatLab analysis
15. Save it as <USB-IF SN>df.tsv ; example: usbd123df
16. If needed give the results in floppy.

B.3.4 Reporting Results

1. Eye: pass/fail
2. Cross Over: pass/fail
3. EOP: pass/fail
4. Receivers:
5. Signal Rate: 1.5 Mb/sec or 12 Mb/sec
6. Jitter:

B.4 Inrush Current Testing

B.4.1 Equipment Used

Note that the equipment listed, the test procedure steps, and the actual list of required tests is expected to change. Please refer to <http://www.usb.org/developers/complian.html> on the USB-IF, Inc. web site for the latest version of this document.

qty	item
1	USB Host System with GPIB board
1	GHOST image for "electrical" Testing
1	oscilloscope
1	TM502A Mainframe
1	50ohm BNC coax line
1	TDS Probes
1	*Current Probes
1	one meter USB cable
1	SQiDD Board

* Older Current Probe and Amplifier, Amps AM503x and Current Probes – P6205 or P6204, obsolete but can be used. Preferred current probe shown in the setup figures are Tektronix A6302 that plug directly into Oscilloscope.

B.4.2 Equipment Setup

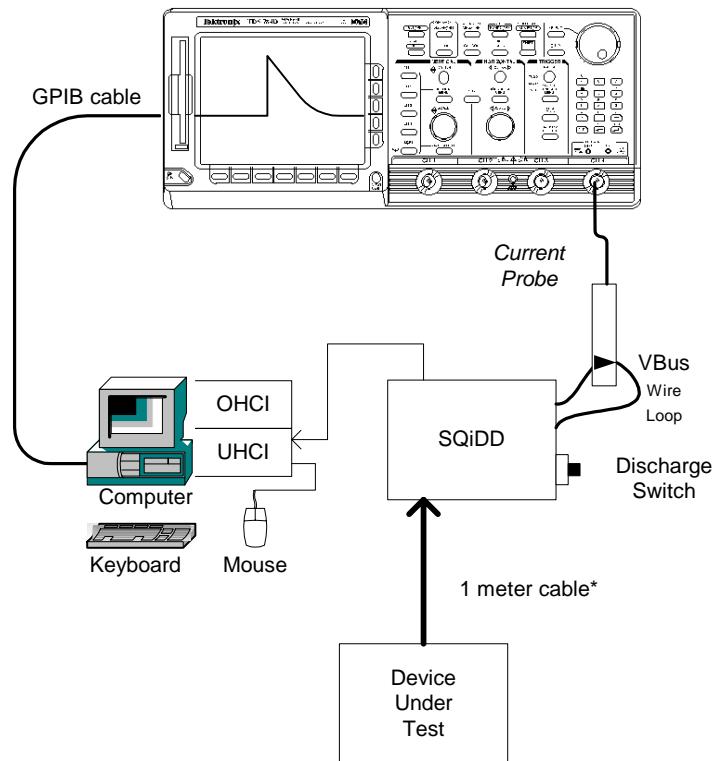

Figure B-8: Device Inrush Current Test Setup

B.4.3 Test Steps

1. Start MatLab and GPIB DAQ (if not already running)
2. On Oscilloscope recall Inrush Current Setup (Setup 5)
3. Unplug current probe from the current breakout board
4. Get zeroes
5. Hook up Device Under Test (DUT) to SQiDD Board Section 1 per Figure B-8: Device Inrush Current Test Setup.
6. Plug back the current probe pointing the arrow downstream
7. Place Switch on SQiDD board to position 3 - shorting V_{BUS} to Gnd on DUT or HUT to discharge stray capacitance
8. Set Trigger level on oscilloscope on channel 4 close to zero

9. Place Switch on SQiDD board to position 1 - Switching V_{BUS} on to DUT or HUT and Plug in DUT or HUT to the SQiDD board
10. Verify signal fits on the display range of scope
If not, adjust vertical range of scope and go to step 6 Otherwise follow step 3
11. Save it as <USB-IF SN>hpi.tsv ; example: usb123hpi
12. After save, press Enter in the MatLab command prompt window
13. Results are displayed along with a plot

These same steps apply to Bus-powered Device operational mode of Self-powered Devices. (Where device operates with power supply disconnected from its AC power source but is still attached to device.)

Self-powered devices are tested and should not have any measurable inrush current.

The analysis aspect of MatLab is done on the data captured with the Oscilloscope, which is setup to measure instantaneous current for a period of time from 500 mS to 1 Second and results in a Pass or Fail report. This is based on the initial current data points used by a device powering up and is analyzed by MatLab software to measure inrush current curve resulting in a measurable micro-coulomb value. The USB spec allows up to 10mF to be hard started that establishes 50.0mC as the maximum inrush current value.

B.4.4 Reporting Results

Describe the inrush test results.

B.5 Hub Downstream Signal Quality Testing

B.5.1 Equipment Used

Note that the equipment listed, the test procedure steps, and the actual list of required tests is expected to change. Please refer to <http://www.usb.org/developers/complian.html> on the USB-IF, Inc. web site for the latest version of this document.

qty	item
1	USB Host System with GPIB board
1	GHOST image for "electrical" Testing
1	oscilloscope
1	TDS Probes
6	five meter USB cable
1	one meter USB cable
1	USB UP BB PCB breakouts
1	USB Down BB PCB breakouts
5	Intel Customer HUB
5	Phihong 5V 4A power Supply (for CHUBs)
1	Intel Create and Share USB Camera
1	mouse

B.5.2 Equipment Setup for testing Downstream Traffic

The best method to capture and analyze full-speed downstream signal quality is to either trigger on SOF packets or use a falling edge trigger on D+.

The best method to capture and analyze low-speed downstream signal quality is to capture both a keep-alive (low speed EOP) and a packet. Hubs are required to generate keep-alives when there is full speed traffic (typically SOF packets) and pass them on to low speed devices with a chance of integrity problems. To capture downstream traffic with low speed devices a trigger on D- or an SE0 pattern trigger is used.

Two channels of the oscilloscope are used.

Setting up Testing of Downstream Traffic

B.5.3 Signal Integrity Test - Downstream Signal test

Hubs produce downstream signals that can be tested.

B.5.3.1 Low-speed Downstream Signal Quality Test

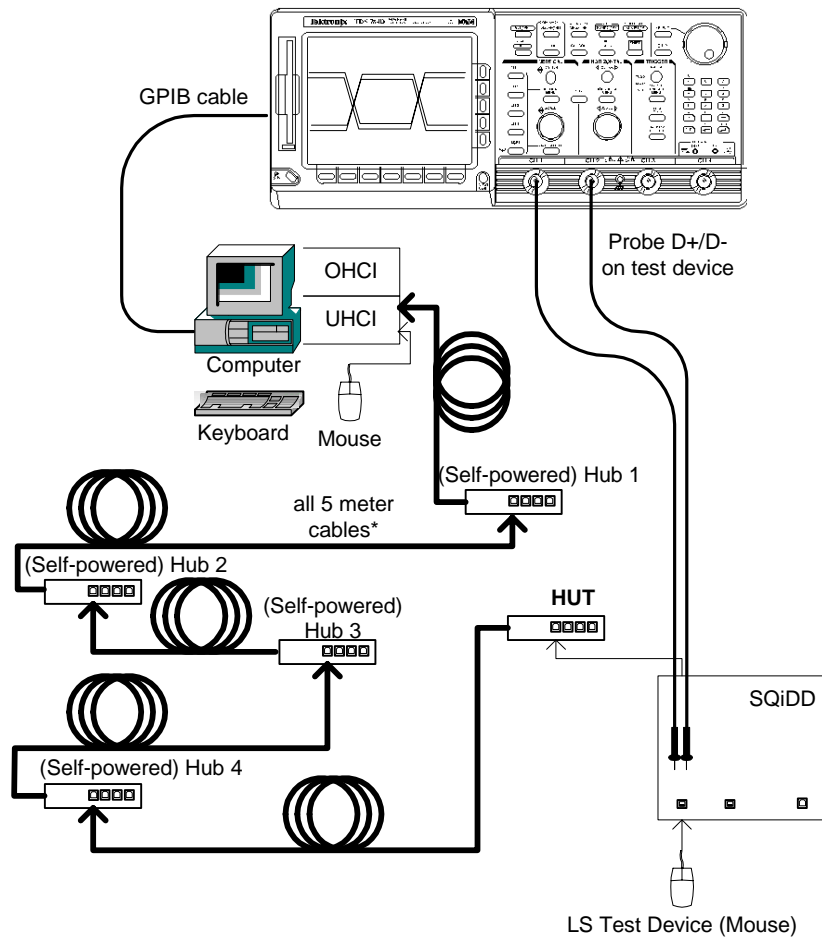

Figure B-9: Hub LS Downstream Signal Quality Test

1. verify the scope is warmed up (running at least 1 hour)
ensure signal path compensation has been run on the scope recently (within 4 hours)
2. Start MatLab
3. Start GPIB DAQ
4. Get zeroes
(Scope must be triggering in order to get zeroes (typically ranges between 50-150mV) and DUT must be unplugged)
5. Quit USBCheck
6. On Oscilloscope recall Setup for Low Speed downstream signal (Setup 3)

7. Unplug hub 5 and plug in HUT and enumerate
8. Connect scope channels 1 and 2 to SQiDD board section 1.
9. Connect SQiDD section 1 'A' plug to a down stream port on the HUT.
10. Plug low speed device to 'A' socket on SQiDD board section 1
11. Low speed device enumerates and drivers are loaded
12. Check scope to make sure waveform has been captured
13. GPIB DAQ auto --> USB Downstream Signals --> no MatLab analysis
14. Save it as <USB-IF SN>.dl.tsv ; example: usbd123dl
15. If needed give the results in floppy.

8. Plug 5 meter cable to one of the downstream ports on the HUT
9. Plug 5 meter cable into 'B' socket on SQiDD board section 3.
10. Enumerate hubs 1 through 4 and the HUT.
11. Start USBCheck
12. Plug 'B' plug from SQiDD board into Full Speed test device and enumerate device
13. Check scope to make sure waveform has been captured
14. GPIB DAQ auto --> USB Downstream Signals --> no MatLab analysis
15. Save it as <USB-IF SN>df.tsv ; example: usbd123df
16. If needed give the results in floppy.

B.5.4 Reporting Results

7. Eye: pass/fail
8. Cross Over: pass/fail
9. EOP: pass/fail
10. Receivers:
11. Signal Rate: 1.5 Mb/sec or 12 Mb/sec
12. Jitter:

B.6 Upstream Signal Quality Testing

B.6.1 Equipment Used

Note that the equipment listed, the test procedure steps, and the actual list of required tests is expected to change. Please refer to <http://www.usb.org/developers/complian.html> on the USB-IF, Inc. web site for the latest version of this document.

qty	item
1	USB Host System with GPIB board
1	GHOST image for "electrical" Testing
1	oscilloscope
3	TDS Probes
6	five meter USB cable
1	SQiDD Board
5	Intel Customer HUB
5	Phihong 5V 4A power Supply (for CHUBs)
1	Intel Create and Share USB Camera
1	mouse

B.6.2 Equipment Setup

Most signal integrity problems occur at the EOP, with the first transition of a packet a close second. Jitter measurements, on the other hand, are most easily done with an entire packet. The simplest measurement technique, and the one the USB-IF uses, is to capture entire packets with a four channel, real-time digital scope. Depending on the signaling speed and the size of the packet, timebases between 10 and 200ns/division are most useful.

B.6.2.1 Setting up Testing of Upstream Traffic

Placing a full speed device downstream of a USB hub allows all downstream signaling from the host to appear on that USB port. With the setup as shown in the UST diagram the DUT upstream signaling is easily distinguished from downstream traffic by observing active traffic on the DUT port while the adjacent device is idle, as upstream traffic is not propagated to downstream ports.

B.6.2.2 Triggering on Upstream Traffic

The start of packet pattern can be captured by setting the scope to trigger on lows on the D+ and D- channels of the DUT's bus segment and a high on the adjacent device's bus segment (when both operate at the same speed). A low speed device will have this on D- line and a full speed device the D+ line. The scope is triggered at an EOP on the DUT's data lines with a J on the adjacent device. If the oscilloscope

supports time-based pattern triggers, requiring the patterns to be true for 10 or more nanoseconds reduces false triggering.

B.6.3 Test Steps

B.6.3.1 Signal Integrity Test - Upstream Signal test (low or full speed)

1. Check the following test setup, Plug in device to tier 5 hub:

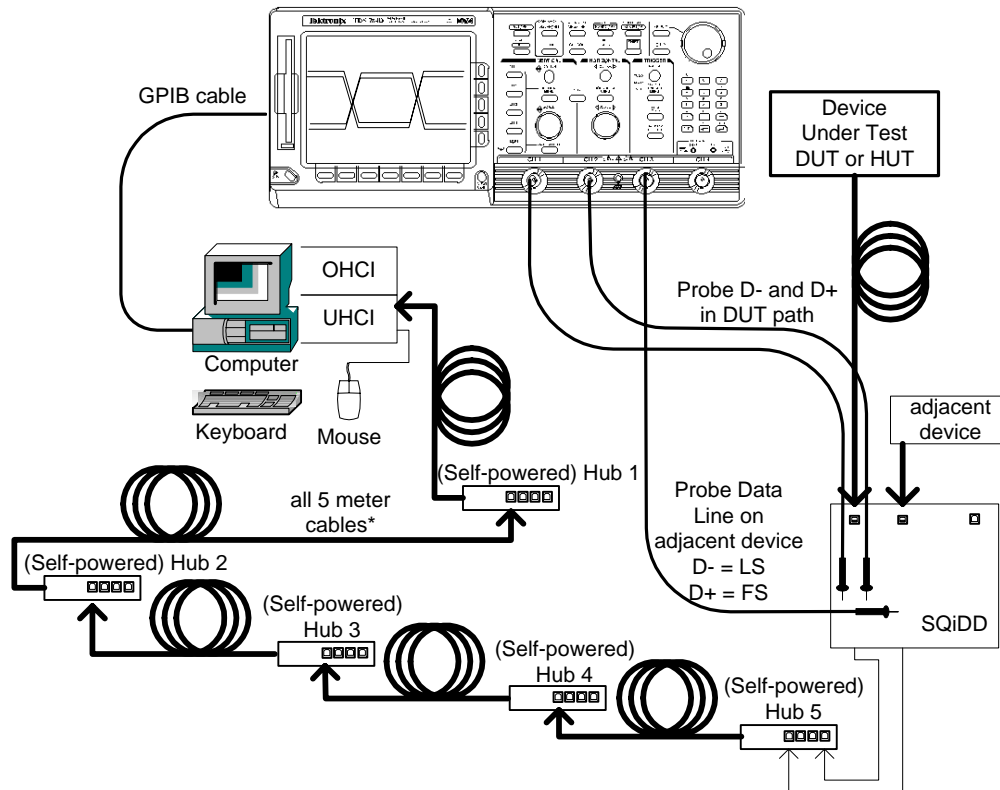

Figure B-11: device and hub upstream signaling test and receiver test schematic

2. Start ULS or UFS Signal Quality Test Run -
 - a) verify the scope is warmed up (running at least 1 hour)
ensure signal path compensation has been run on the scope recently (within 4 hours)
 - b) Start MatLab script
 - c) Start GPIB DAQ

- d) Get zeroes
Scope must be triggering in order to get zeros (typically ranges between 50-150mV) and DUT must be unplugged
- e) Start USBCheck
- f) On the Oscilloscope recall Setup for Upstream Low Speed or Upstream Full Speed (Setup 1 or Setup 2 respectively)
- g) Connect probes:

Channel 1 D-, Channel 2 D+
If running Upstream **low speed** test connect Channel 3 to **D-**
If running Upstream **Full speed** test connect Channel 3 to **D+**
- h) Plug in the adjacent device to SQiDD board section 2 and make sure it enumerates in USBCheck.
- i) Plug in DUT to SQiDD board section 1; select the device in USBCheck
- j) Run Full chapter 9 test to make sure the device passes the test
- k) Check the scope to make sure waveform has been captured

Use vertical cursor to select a signal packet
- l) GPIB DAQ auto → USB (low or Full Speed) Upstream Signal →6 tier
Record the number of the tier where the DUT reliably enumerates.
- m) Save it as <USB-IF SN>.tsv ; example: usbd123u
- n) After save, press Enter in the MatLab command prompt window
- o) Plots are displayed and results are on the MatLab command prompt window
- p) If needed save results to floppy.

B.6.4 Reporting Results

- 1. Eye: pass/fail
- 2. Cross Over: pass/fail
- 3. EOP: pass/fail
- 4. Receivers:

5. Signal Rate: 1.5 Mb/sec or 12 Mb/sec
6. Jitter:

B.6.4.1 Online Directory Structure

All Test Data is saved on the D drive. The parent directory is named with corresponding month and year. Sub-directories are named with the corresponding month and date.

sept1999	(parent directory)
sept14	(Subdirectory)
sept15	(Subdirectory)
sept16	(Subdirectory)

B.6.4.2 Test Data Naming Convention

Signal quality and inrush current testing generates at least one data file, often more. All data files are in tab separated value format (TSV) and can be imported by any number of analysis tools.

These files are:

<USB-IF SN>u.tsv	Upstream Signals (Low or Full Speed)
<USB-IF SN>dl.tsv	Low Speed Downstream Signal (Hubs and Systems)
<USB-IF SN>df.tsv	Full Speed Downstream Signal (Hubs and Systems)
<USB-IF SN>hpi.tsv	Hot Plug Inrush Current

Where <USB-IF SN> is the device or system's USB-IF serial number. During Plugfest testing, upstream signal and hot plug inrush current files are processed by MATLAB analysis scripts. These scripts generate HTML report files, <USB-IF SN>u.html and <USB-IF SN>hpi.html, as well as the .png (Portable Network Graphics, also known as "pings") images used in reports.

C Device Framework Testing

C.1 Equipment Used

Note that the equipment listed, the test procedure steps, and the actual list of required tests is expected to change. Please refer to <http://www.usb.org/developers/complian.html> on the USB-IF, Inc. web site for the latest version of this document.

item	description/model	qty
USB Host System	Hardware Configuration: TBD	1
CATC UHT	automated USB hub tester – firmware 1.6 or later	2
Entrega Hub (Self-powered)	Hub4U	2
Imation SuperDisk(tm) Drive	Order Number 0-51122-40810-6	1
Intel Create and Share USB Camera	P/N 735147-001, Model#: CS330	1
KC Tech 1.1 Hub	WTC-6010S version 1.0	1
MS Internet Keyboard Pro (TI Hub)	Keyboard RT9420 V 5FTW	1
mouse	Logitech mouse P/N 830311-1000, Model#: M-BB48	8
Newnex Hub (Self-powered)	Model#: BT6AT01	1
one meter USB cables	any listed on USB-IF Cables and Connectors Integrators List	3
five meter USB cables	any listed on USB-IF Cables and Connectors Integrators List	6

C.2 Equipment Setup

C.2.1 Prepare the Host System

The host software required is Windows 2000 Professional and the USBCheck tool. Either restore the saved image of the previously prepared system or follow the steps given in the following sections.

C.2.1.1 Install Windows 2000 Professional

Use the default installation options: select 'typical' system configuration, install 'most common components', and select location 'US'.

Install any required platform-specific drivers – all devices should be 'working properly'; there should be no 'unknown devices' shown in the Windows 2000 Device Manager.

C.2.1.2 Install USBCheck

Run the USBComp.exe installation package from USB-IF, Inc. to install the USBCheck-related tools.

C.3 Test Steps

C.3.1 All Devices

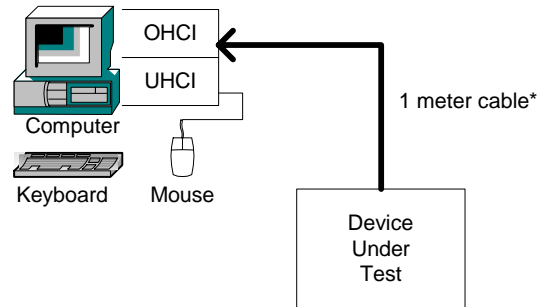

Figure C-1: Device Framework Testing

When testing a device with a removable cable use either the cable supplied by the manufacturer or a one meter cable.

1. Start USBCheck/Chap9
2. Connect the device to port 1 of the OHCI host controller using either the cable supplied by the manufacturer or a one meter cable.
3. If the system asks for drivers point to c:\winnt\system32\drivers
4. Run full test
5. Record....
 - Pass/Fail results
 - Max Power value
 - Number of Interfaces

C.3.2 Non-Hub Devices

If the device has one or more HID interfaces run USBCheck/HIDView.

Select HIDView tab

You will be prompted to disconnect/connect device

Select a HID interface

Run full test

Record Pass/Fail results

Repeat steps 3, 4 and 5 for any additional HID interfaces.

C.3.3 Small Hubs (4 Ports or Less)

Connect the cables from one CATC UHT Hub Tester to downstream ports on the hub. If the hub ports are not labeled you will have to use USBCheck to discover each port number.

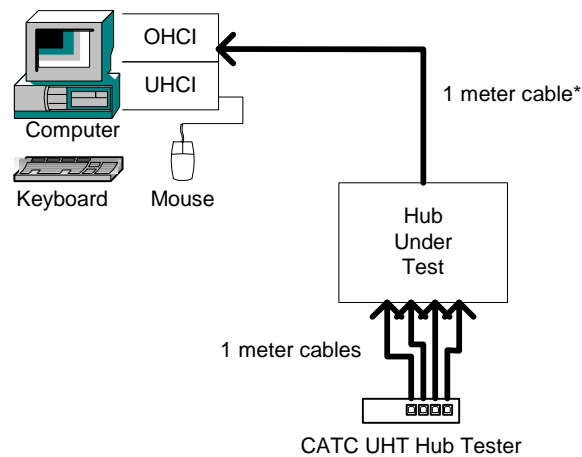

Figure C-2: 4 Port or Smaller Hub with CATC UHT Hub Tester

Select the Chap11 tab

Run full automated test

If all tests Pass, Record Results and skip further steps in this section

If unit Fails (or CATC UHT is unavailable), remove CATC UHT Hub Tester and connect a mouse nest to the hub's downstream ports

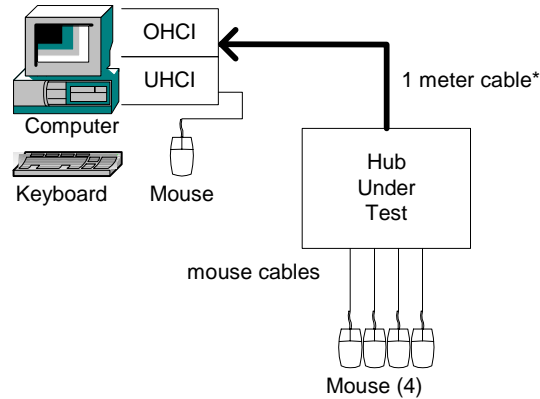

Figure C-3: 4 Port or Smaller Hub with Mouse Nest

Re-run the full Chap11 test set manually (clear CATC option)

Record Pass/Fail results

C.3.4 Large (Self-Powered) Hubs (More than 4 Ports)

1. Connect the cables from both CATC UHT Hub Testers to downstream ports on the hub. If the hub ports are not labeled you will have to use **USBCheck** to discover each port number.

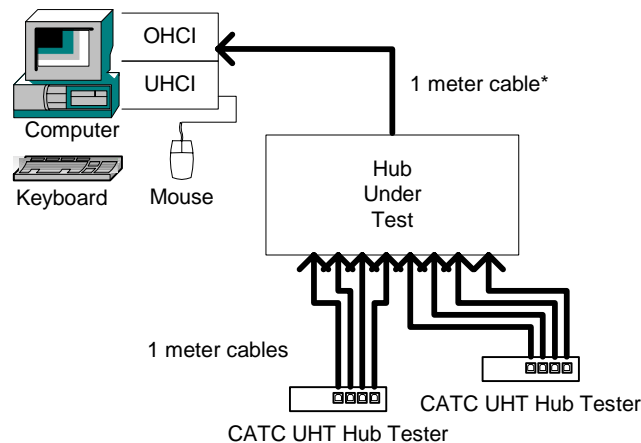

Figure C-4: Large (5-8 Port) Hub with pair of CATC UHT Hub Testers

2. Select the Chap11 tab
3. Run full automated test
4. If all tests Pass, Record Results and skip further steps in this section

5. If unit Fails (or CATC UHT are unavailable), remove CATC UHT Hub Testers and connect a large mouse nest to each of the hub's downstream ports

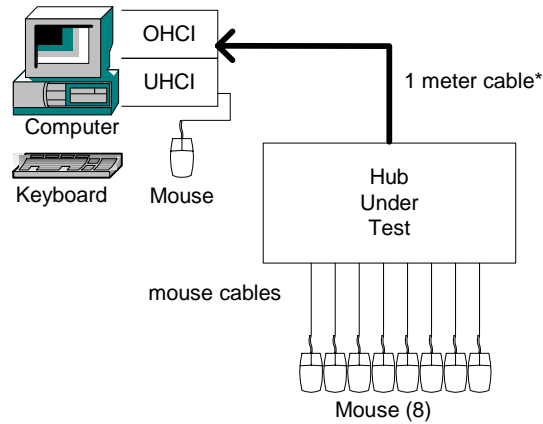

Figure C-5: Large (5 to 8 Port) Hub with Mouse Nest

6. Re-run the full Chap11 test set manually (clear CATC option)
7. Record Pass/Fail results

C.3.5 Hubs with Embedded Devices

1. After completing testing of the hub (as detailed in the sections above), unplug the hub under test.
2. Select the "ignore hubs" option in the *USBCheck* program.

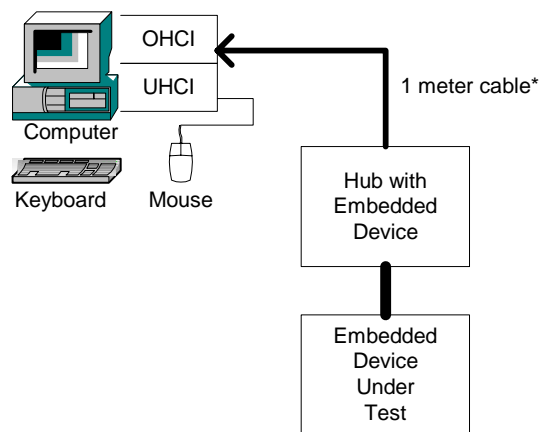

Figure C-6: Hub with Embedded Device

3. Re-connect the hub – the embedded device will be captured by *USBCheck*
4. Run full test

5. If the system asks for drivers point to c:\windows\system32\drivers
6. Record....
 - Pass/Fail results
 - Max Power value
 - Number of Interfaces

C.4 Reporting Results

1. Number of Interfaces: (number must be greater than zero)
2. Max Power: If self-powered 100 mA or less, if bus-powered 500 mA or less
3. Remote WakeUp Support: Yes/No
4. Chapter 9 comments: text
5. Chapter 11 test results: Pass/Fail/NA
6. Compound Device: Yes/No
7. Chapter 11 comments: text
8. HIDView test results: Pass/Fail/NA
9. HIDView comments: text

D Windows 2000 Peripheral Interoperability Testing

D.1 Equipment Used

Note that the equipment listed, the test procedure steps, and the actual list of required tests is expected to change. Please refer to <http://www.usb.org/developers/complian.html> on the USB-IF, Inc. web site for the latest version of this document.

item	description/model	qty
USB Host System	Hardware Configuration: TBD	1
average current draw test jig	[test fixture acquired through USB-IF, Inc.]	1
Entrega Hub (Self-powered)	Hub4U	2
Imation SuperDisk(tm) Drive	Order Number 0-51122-40810-6	1
Intel Create and Share USB Camera	P/N 735147-001, Model#: CS330	1
KC Tech 1.1 Hub	WTC-6010S version 1.0	1
MS Internet Keyboard Pro (TI Hub)	Keyboard RT9420 V 5FTW	1
mouse	Logitech mouse P/N 830311-1000, Model#: M-BB48	8
Newnex Hub (Self-powered)	Model#: BT6AT01	1
one meter USB cables	any listed on USB-IF Cables and Connectors Integrators List	3
five meter USB cables	any listed on USB-IF Cables and Connectors Integrators List	6



Figure D-1: Average Current Draw Test Jig

D.2 Equipment Setup

D.2.1 Prepare the Host System

The host software required is Windows 2000 Professional and the USBCheck tool. Either restore the saved image of the previously prepared system or follow the steps given in the following sections.

D.2.1.1 Install Windows 2000 Professional

Use the default installation options: select 'typical' system configuration, install 'most common components', and select location 'US'.

Install any required platform-specific drivers – all devices should be 'working properly'; there should be no 'unknown devices' shown in the Windows 2000 Device Manager.

D.2.1.2 Install USBCheck

Run the USBComp.exe installation package from USB-IF, Inc. to install the USBCheck-related tools.

D.2.2 Initialize the Gold Tree

The Gold Tree devices are arranged:

- Hub 1 – Newnex Hub (Self-powered)
- Hub 2 – MS Internet Keyboard Pro (TI Hub) on port 1 of Newnex
- Logitech mouse on port 2 of MS Internet Keyboard Pro
- Hub 3 – Entrega Hub on port 3 of MS Internet Keyboard Pro
- Hub 4 – KC Tech Hub on port 1 of Hub 3 (Entrega Hub)
- Hub 5 – Entrega Hub on port 1 of KC Tech Hub
- Intel camera on port 1 of Hub 5 (Entrega Hub)
- Imation Superdisk on port 2 of Hub 5 (Entrega Hub)

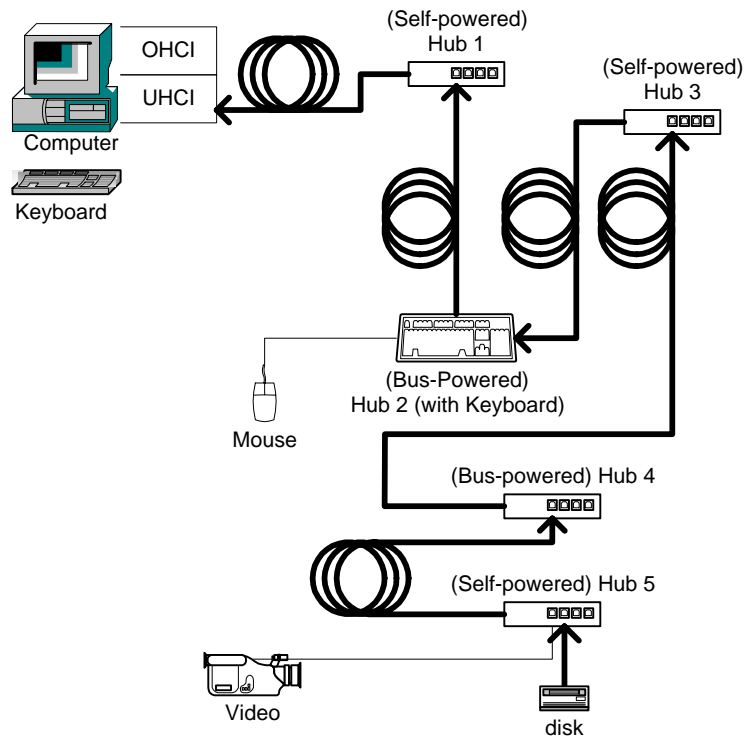

Figure D-2: Interoperability Gold Tree

Attach the Gold Tree to port #1 on the OHCI root hub. Verify that all the devices are operating properly by starting the appropriate applications: read data from the disk, show images from the video camera, type on the keyboard and move the mouse. Shut down all applications.

Unplug the Gold Tree from the OHCI root hub and connect the Gold Tree to port #1 on the UHCI root hub. Verify that all the devices are operating properly by starting the appropriate applications: read data

from the disk, show images from the video camera, type on the keyboard and move the mouse. Shut down all applications.

D.3 Test Steps

D.3.1 Non-Hub Devices

1. Plug in the device to the open port on Hub 5. Use a 5 meter cable if the device uses a removable cable.

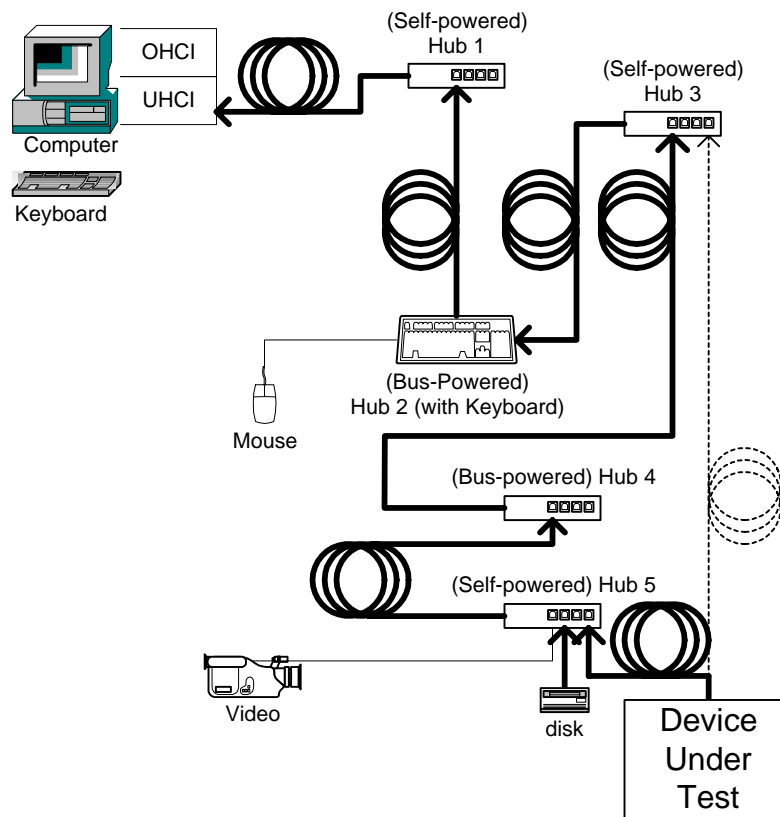

Figure D-3: Device Interoperability

2. Enumeration test
If the device is recognized by the OS use the support included in the GHOST image [Windows 2000]. DO NOT install drivers from any vendor-supplied driver disk or CD at this time. Use only the drivers provided in the GHOST image for Device Interoperability Testing in this step.

If the OS indicates that it does not include support for this device, install the drivers provided on a vendor-supplied driver disk or CD now.

- Pass

- 1 Device enumerates with the 5 meter cable (if cable is not captive)
AND
- 2 Device enumerates below hub #5
AND
- 3 Driver installs with an .inf file (provided on a floppy or a CD) or is enumerated automatically by the system (class driver)
AND
- 4 Device under test does not require a reboot (except networking devices)
AND
- 5 Device under test is correctly identified by Device Manager

- Fail

- 1 Device under test requires driver installation or application software BEFORE device under test is plugged in
OR
- 2 Driver blue screens during enumeration
OR
- 3 Device under test requires reboot (and is not a networking device)
OR
- 4 Device under test is incorrectly identified by Device Manager
OR
- 5 Device under test does not enumerate below hub #5
OR
- 6 (If cable is not captive) Device cannot enumerate with 5 meter cable

3. Install any additional software

- Pass

- 1 Software installs without blue screens,
a) No reboot required
OR
b) Justification for reboot:
- 2 No software required

- Fail

- 1 Installation software blue screens / crashes system.

4. Device Under Test Demonstrates Operation Connected To Hub #5 with the 5 meter cable (if cable not captive).

- Pass
 - 1 Device operates as expected with the 5 meter cable (if cable not captive).

- Fail
 - 1 Device fails to operate
OR
 - 2 Device / application blue screens / crashes system
OR
 - 3 Device operates as expected but not when installed below Hub #5

5. Update Driver (if applicable)

If there is a vendor-supplied driver disk or CD

AND

the drivers installed in step 1 were part of the GHOST image (i.e. the drivers were not loaded from the vendor-supplied driver disk or CD), update the driver using Device Manager.

(else skip to step 7)

- Pass
 - 1 Driver is updated successfully with NO blue screens
AND
 - 2 No reboot is required unless device is a networking device
AND
 - 3 New driver is reported correctly in Device Manager

- Fail
 - 1 Any blue screen of death
OR
 - 2 Device under test requires reboot (and is not a networking device)
OR
 - 3 New driver is not reported correctly in Device Manager

6. Demonstrate operation with updated driver (if applicable)

- Pass
 - 1 Device operates as expected with the 5 meter cable (if cable not captive).

- Fail
 - 1 Device fails to operate
OR
 - 2 Device / application blue screens / crashes system
OR
 - 3 Device operates as expected but not when installed below Hub #5

7. Active Suspend

Stop! Disable the OHCI host controller using the device manager. [Windows 98SE]

– While device under test is in operation/use, suspend system. (Using keyboard, press windows button, start menu comes up, press, “u”, and then “return”.) System is placed in S3.

- Pass
 - 1 System suspends (Skip test #6)
OR
 - 2 System notifies user that the system cannot go into suspend (Go to test #6)
- Fail
 - 1 System blue screens / locks up

8. Inactive Suspend – No devices in use, suspend system by pressing sleep key on MS Internet Keyboard Pro keyboard (upper left corner). System is placed in S3.

- Pass
 - 1 System suspends
- Fail
 - 1 System blue screens / locks up
OR
 - 2 System fails to enter standby

- ## 9. Functionality after wakeup / resume – Check if device under test still operates.
- If device under test is a remote wakeup device, use it to wake up the system, otherwise use USB keyboard or mouse.
Test functionality of device under test.

- Pass
 - 1 If device under test is a remote wakeup device, device under test wakes up system
AND
 - 2 Device under test operates as in step #4

- Fail
 - 1 If device is a remote wakeup device and fails to wake up the system
OR
 - 2 Device under test fails to operate as in step #4

10. Switch Testing to OHCI

Stop! Enable the OHCI host controller using the device manager. [Windows 2000]

- Disconnect gold tree from onboard UHCI controller
- Connect entire tree to OHCI root port #1
- Enumerate device under test below hub #5 with the 5-meter cable if cable not captive

- Pass
 - 1 Device enumerates with the 5 meter cable (if cable not captive)
AND
 - 2 Device enumerates below hub #5
AND
 - 3 Driver installs with an .inf file (provided on a floppy or a CD) or is enumerated automatically by the system (class driver)
AND
 - 4 Device under test does not require a reboot (except networking devices)
AND
 - 5 Device under test is correctly identified by Device Manager

- Fail
 - 1 Device under test requires driver installation or application software BEFORE device under test is plugged in
OR
 - 2 Driver blue screens during enumeration
OR
 - 3 Device under test requires reboot (and is not a networking device)
OR
 - 4 Device under test is incorrectly identified by Device Manager
OR
 - 5 Device under test does not enumerate below hub #5
OR

- 6 (If cable is not captive) Device cannot enumerate with 5 meter cable

11. Interoperability

Run each individual device in Gold Tree.

Check that device under test functions while other devices are operating.

- Pass

- 1 Device under test operates as in step #4
AND
- 2 Gold Tree devices all operate

- Fail

- 1 Device under test fails to operate as in step #4
OR
- 2 One or more Gold Tree devices fail to operate

12. Interoperability – Mouse Enumeration Test

While device under test is operating, camera is streaming, and mpeg/avi file is playing from mass storage device:

- Disconnect and reconnect Logitech mouse in same port in the MS Internet Keyboard Pro/hub
- Check that device under test functions while the gold tree devices are operating

- Pass

- 1 Device under test operates as in step #4
AND
- 2 Gold Tree devices all operate

- Fail

- 1 Device under test fails to operate as in step #4
OR
- 2 One or more Gold Tree devices fail to operate

13. Hot Detach & Reattach

Stop Device operation!

Detach and reattach device under test to same hub port.
Test functionality of device under test only.

- Pass

1 Device under test operates as in step #4

- Fail

1 Device under test fails to operate as in step #4

14. Topology Change

Stop Device operation!

Detach and reattach device under test to an open port on Hub #3.
Test functionality of device under test only.

- Pass

1 Device under test operates as in step #4

- Fail

1 Device under test fails to operate as in step #4

15. Warm boot

Restart system through the start menu (Start -> Shutdown -> Restart).
Test functionality of device under test after system reboots.

- Pass

1 Device under test operates as in step #4

- Fail

1 Device under test fails to operate as in step #4

16. Cold boot

Restart system through the start menu (Start -> Shutdown -> Shutdown).
Turn PC back on.
Test functionality of device under test after system reboots.

- Pass

1 Device under test operates as in step #4

- Fail

1 Device under test fails to operate as in step #4

D.3.2 Hubs

All hubs must pass the extended operability tests. Self-powered hubs must also pass the self-powered hub tests; bus-powered hubs must also pass the bus-powered hub tests. Hubs which operate in both bus- and self-powered modes must pass all three tests.

D.3.2.1 Self-Powered Hub Tests

1. Enumerate Hub

If hub under test has an embedded hub:

- Disconnect hub #4 from hub #3
- Connect hub under test to hub #3 with 5 meter cable.

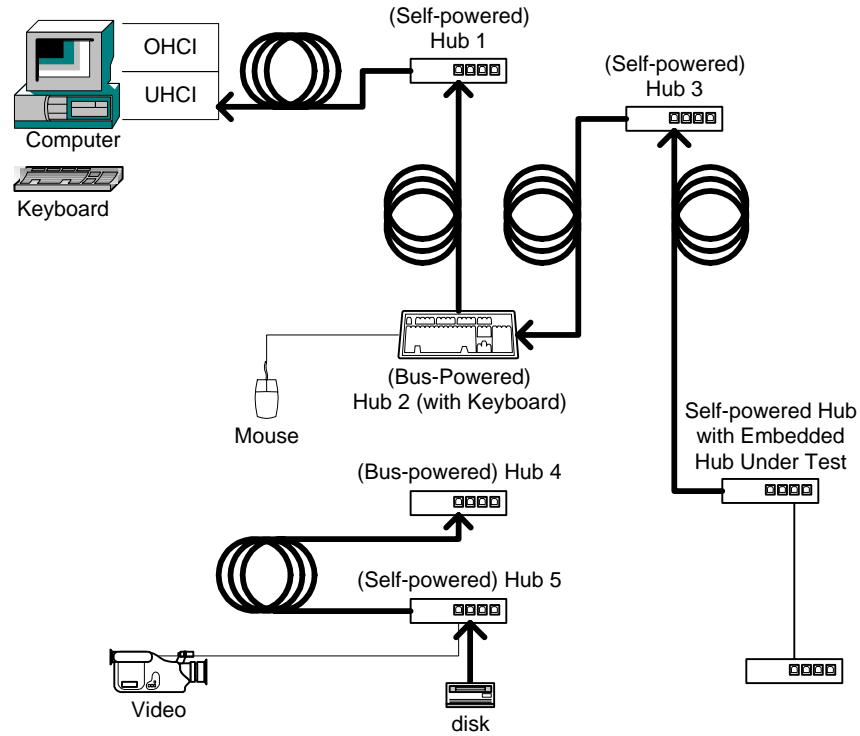

Figure D-4: Hub with Embedded Hub

Otherwise:

- Disconnect hub #5 from hub #4
- Connect hub under test to hub #4 with 5 meter cable.

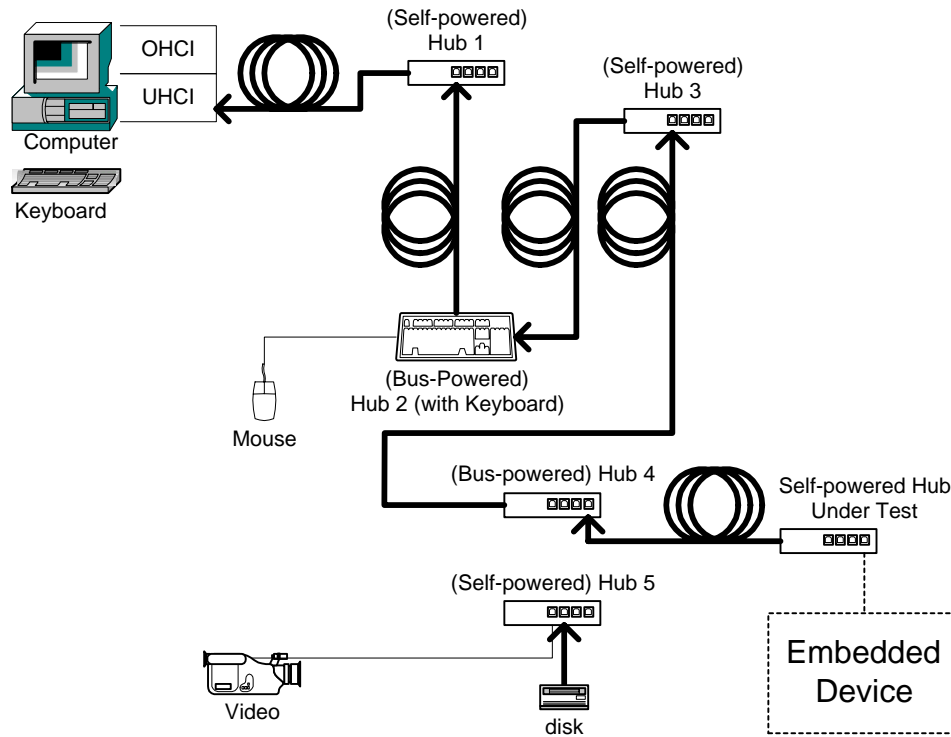

Figure D-5: Self-powered Hub Interoperability

- Pass
 - 1 Hub under test enumerates with the 5 meter cable
AND
 - 2 Hub under test enumerates below hub #3 if has embedded hub else hub #4
AND
 - 3 Hub under test does not require a reboot
AND
 - 4 Hub under test is correctly identified by Device Manager

- Fail
 - 1 Hub under test requires reboot (and is not a networking device)
OR
 - 2 Hub under test is incorrectly identified by Device Manager (for example, such as "Unknown Device" or "Other Device")
OR

- 3 Hub under test does not enumerate below hub #3 if hub has embedded hub else hub #4
OR
- 4 Hub cannot enumerate with 5 meter cable

3. Load driver and application for embedded function (if applicable).

- Pass

- 1 Driver and application software installs without blue screens (reboots allowed for application software, device if a networking device ONLY)
OR
- 2 No software required

- Fail

- 1 Installation software blue screens / crashes system
OR
- 2 Driver for embedded device requires reboot (except networking devices)

2. Test embedded function in Hub Under Test (if applicable)

- Pass

- 1 Embedded device operates as expected
OR
- 2 No embedded device

- Fail

- 1 Embedded device does not operate as expected OR
OR
- 2 Blue screen / locks up / system crash

4. Move devices that were connected to the disconnected Hub to the Hub Under Test

If hub under test has an embedded hub:

- move devices that were connected to hub #4 to first tier of hub under test
- move devices that were connected to hub #5 to embedded hub

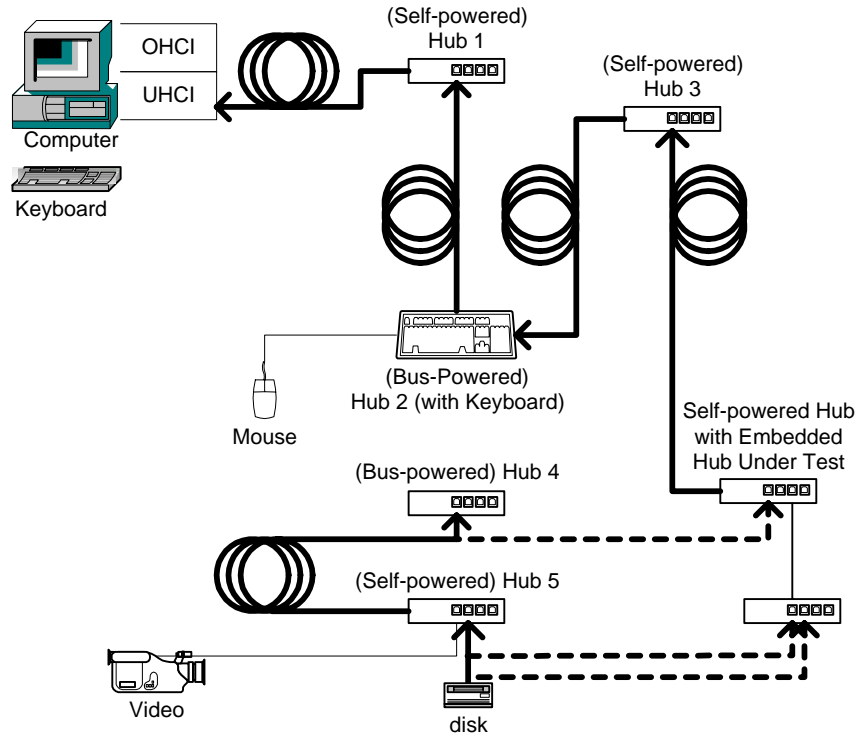

Figure D-6: Move Devices to Hub and Embedded Hub

Otherwise

- move devices that were connected to hub #5 to hub under test

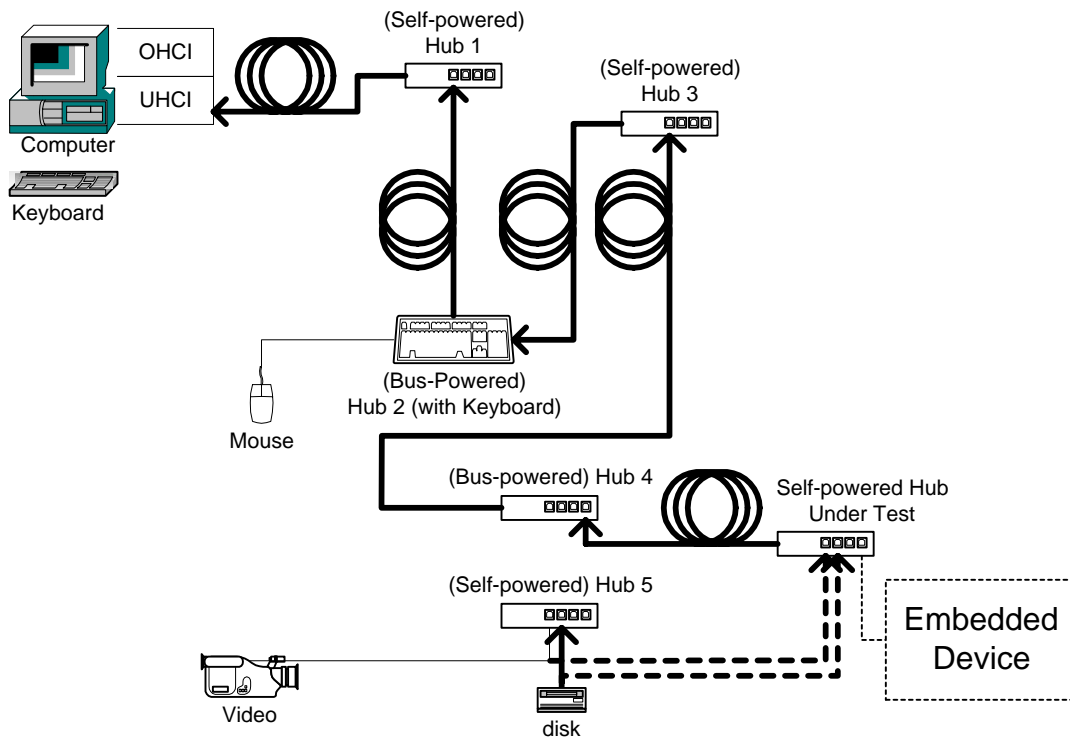

Figure D-7: Hub with Embedded Device (non-Hub)

- Pass
 - 1 Embedded device operates as expected
OR
 - 2 No embedded device
- Fail
 - 1 Embedded device does not operate as expected
OR
 - 2 Blue screen / locks up / system crash

5. Interoperability

- Test All Devices, including embedded device if applicable, simultaneously

- Pass

**For Review and Discussion Only
Draft Document Subject to Revision or Rejection
Not For Publication or General Distribution**

- 1 Every device operates as expected
- Fail
 - 1 One or more device does not operate as expected
OR
 - 2 Blue screen / locks up / system crash

D.3.2.2 Bus-Powered Hub Tests

1. Enumerate Hub

Connect with the 5 meter cable Hub Under Test To Hub #3

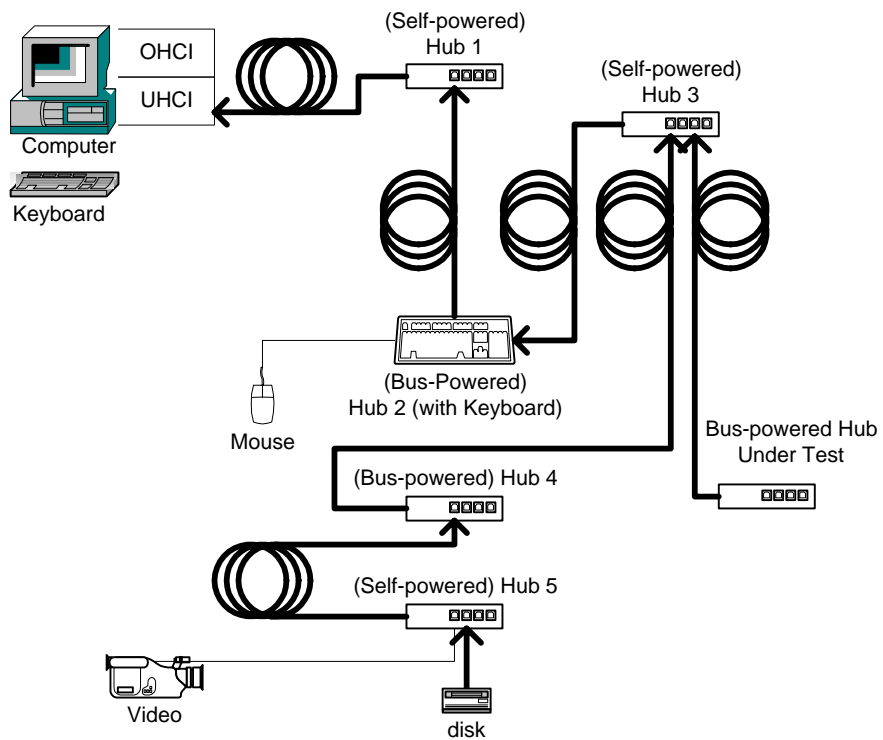

Figure D-8: Bus-powered Hub Interoperability

- Pass
 - 1 Hub under test enumerates with the 5 meter cable
AND
 - 2 Hub under test enumerates below hub #3
AND

- 3 Hub under test does not require a reboot
AND
- 4 Hub under test is correctly identified by Device Manager

- Fail

- 1 Hub under test requires reboot (and is not a networking device)
OR
- 2 Hub under test is incorrectly identified by Device Manager (for example, such as “Unknown Device” or “Other Device”)
OR
- 3 Hub under test does not enumerate below hub #3 if hub has embedded hub else hub #4
OR
- 4 Hub cannot enumerate with 5 meter cable

2. Load driver and application for embedded function (if applicable).

- Pass

- 1 Driver and application software installs without blue screens (reboots allowed for application software, device if a networking device ONLY)
OR
- 2 No software required

- Fail

- 1 Installation software blue screens / crashes system
OR
- 2 Driver for embedded device requires reboot (except networking devices)

3. Test embedded function in Hub Under Test (if applicable)

- Pass

- 1 Embedded device operates as expected
OR
- 2 No embedded device

- Fail

- 1 Embedded device does not operate as expected OR
OR
- 2 Blue screen / locks up / system crash

6. Move devices that were connected to the disconnected Hub, including the disconnected Hub to the Hub Under Test

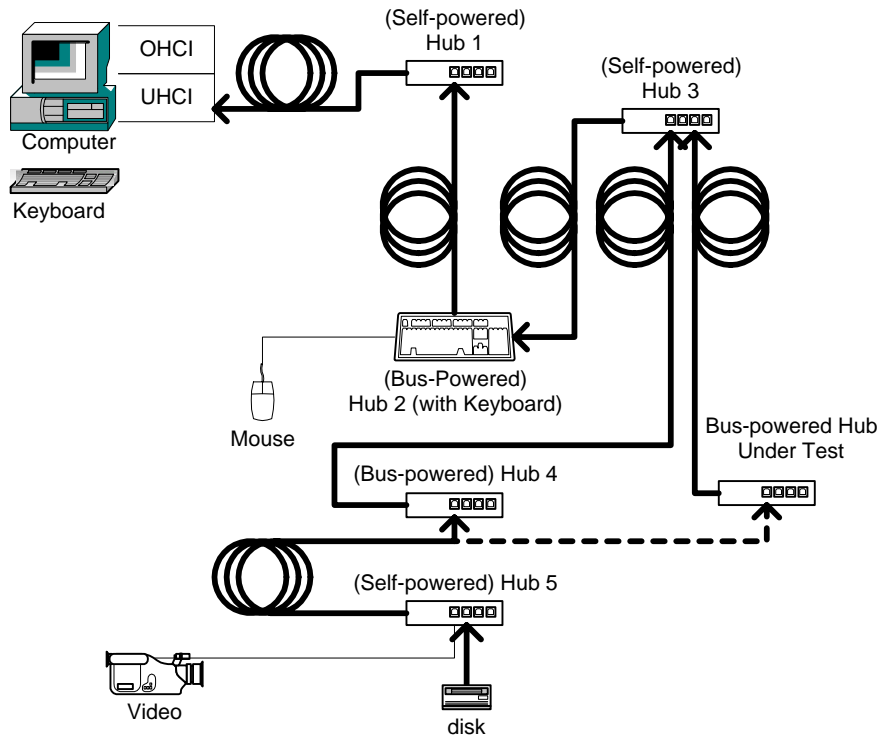

Figure D-9: Add Devices Below Hub Under Test

- Pass
 - 1 All devices enumerate properly
- Fail
 - 1 One or more device does not enumerate
OR
 - 2 Blue screen / locks up / system crash

3. Interoperability

- Test All Devices, including embedded device if applicable, simultaneously

- Pass

- 1 Every device operates as expected
- Fail
- 1 One or more device does not operate as expected
OR
 - 2 Blue screen / locks up / system crash

D.3.2.3 Extended Operability Tests

1. Hot Detach and Reattach

Stop operation of any embedded device and all devices attached below hub under test!

- Detach and reattach hub under test to same hub port

- Pass
- 1 Every device operates as expected
- Fail
- 1 One or more device does not operate as expected
OR
 - 2 Blue screen / locks up / system crash

2. Suspend

Stop! Disable the OHCI host controller using the device manager. [Windows 2000]

- If hub has embedded function, while embedded function is in operation/use, suspend system by pressing sleep key on MS Internet Keyboard Pro keyboard (upper left corner).

- If embedded function prevents suspend, stop operation of embedded function and repeat previous step.

- Pass
- 1 System suspends
- Fail

- 1 System cannot enter suspend (even when embedded function is inactive)
OR
- 2 System blue screens / locks up

3. System Resume

- Use embedded function to wakeup system if a wakeup device
- Test all devices after resume

- Pass

- 1 System resumes
AND
- 2 All devices operate correctly

- Fail

- 1 One or more device fails to operate correctly
OR
- 2 System fails to resume

4. Connect to OHCI

Stop! Enable the OHCI host controller using the device manager. [Windows 2000]

- Test all devices after connection of the tree to the OHCI root hub.

- Pass

- 1 All devices enumerate
AND
- 2 All devices operate correctly

- Fail

- 1 One or more device fails to enumerate
OR
- 2 One or more device fails to operate correctly

5. Warm Boot

Restart system through the start menu (Start -> Shutdown -> Restart).
Test functionality of all devices after system reboots.

- Pass

- 1 All devices operate correctly
- Fail
 - 1 One or more device fails to operate correctly
OR
 - 2 System fails to reboot

6. Cold Boot

Restart system through the start menu (Start -> Shutdown -> Shutdown).
Turn PC back on.
Test functionality of all devices after system reboots.

- Pass
 - 1 All devices operate correctly
- Fail
 - 1 One or more device fails to operate correctly
OR
 - 2 System fails to reboot

D.3.3 Measuring Average Current Draw

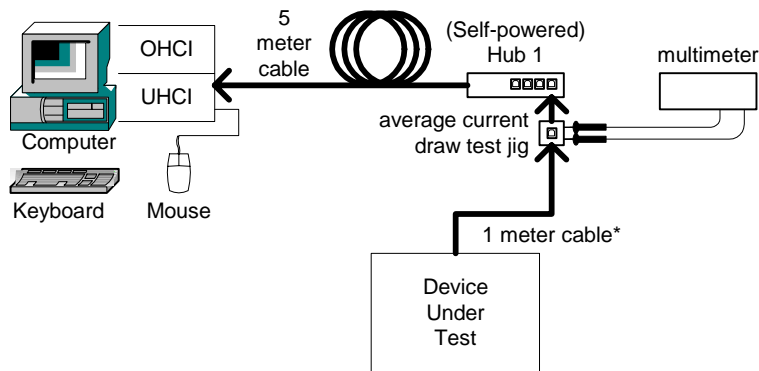

Figure D-10: Average Current Measurement

1. Measure current in Address state (not configured)
 - start USBCheck/Chap9
 - plug the Device or Hub under test into the average current draw test jig

**For Review and Discussion Only
Draft Document Subject to Revision or Rejection
Not For Publication or General Distribution**

- verify that the device is operating by reading its descriptors
- record the average current shown on the multimeter as 'not configured current'

- Pass

- 1 measured current is 100 mA or less

- Fail

- 1 measured current exceeds 100 mA

2. Measure current in Configured state

- exit USBCheck
- unplug and replug the Device or Hub under test into the average current draw test jig
- verify that the device enumerates and is correctly identified by Device Manager
- record the average current shown on the multimeter as 'configured current'

- Pass

- 1 measured current is less than the value recorded during device framework testing

- Fail

- 1 measured current exceeds the value recorded during device framework testing

3. Measure current under normal operation

- use the device, verify that it is operating normally
- record the average current shown on the multimeter as 'operating current'

- Pass

- 1 measured current is less than the value recorded during device framework testing

- Fail

- 1 measured current exceeds the value recorded during device framework testing

4. Measure current when device is suspended

Stop! Disable the OHCI host controller using the device manager. [Windows 2000]

- suspend system by pressing sleep key on MS Internet Keyboard Pro keyboard (upper left corner).
- If embedded function prevents suspend, stop operation of embedded function and repeat previous step.
- record the average current shown on the multimeter as 'suspend current'

- Pass

- 1 measured current is 500 μ A or less
OR
- 2 device is configured for high-power
AND device is enabled as a remote wakeup device
AND measured current is 2.5 mA or less

- Fail

- 1 measured current exceeds 500 μ A AND device is configured for operation with low-power
OR
- 2 measured current exceeds 2.5 mA

D.4 Reporting Results

D.4.1 Interoperability Results

Non-Hub Test Results

1. Enumerate Device: PASS/FAIL
2. Install Additional Software PASS/FAIL
3. DUT Demonstrates Operation PASS/FAIL
4. Active Suspend: PASS/FAIL/not supported
5. InActive Suspend: PASS/FAIL/NA
6. Functionality After WakeUp-Resume: PASS/FAIL
7. Switch Testing to OHCI: PASS/FAIL

Interoperability

1. Interoperability - Mouse Enumeration Test: PASS/FAIL
2. Hot Attach & Reattach: PASS/FAIL

3. Topology Change: PASS/FAIL
4. Warm Reboot: PASS/FAIL
5. Cold Reboot: PASS/FAIL

OVERALL HUB RESULTS

Self-powered Hub Results: PASS/FAIL/NA
Self-powered-Enumerate Hub: PASS/FAIL/NA

Self-powered-Load Driver & Application: PASS/FAIL/NA

Self-powered-Test Embedded function in HUT: PASS/FAIL/NA

Self-powered-Move Device: PASS/FAIL/NA

Self-powered-Interoperability: PASS/FAIL/NA

Bus-powered Hub Results: PASS/FAIL/NA

Bus-powered-Enumerate Hub: PASS/FAIL/NA

Bus-powered-Load Driver & Application: PASS/FAIL/NA

Bus-powered-Test Embedded function in HUT: PASS/FAIL/NA

Bus-powered-Move Device: PASS/FAIL/NA

Bus-powered-Interoperability: PASS/FAIL/NA

Extended Operability Test Results: PASS/FAIL/NA

Ex-Hot Detach and Reattach: PASS/FAIL/NA

Ex-Suspend: PASS/FAIL/NA

Ex-System Resume: PASS/FAIL/NA

Ex-Warm Reboot: PASS/FAIL/NA

Ex-Cold Reboot: PASS/FAIL/NA

Interoperability Comments: [text]

D.4.2 Current Measurement Results

1. Self-powered – unconfigured current: passing value is 100 mA or less
2. Self-powered – configured current: passing value is 100 mA or less
3. Self-powered – suspend current: passing values are 500 μ A or less
4. Self-powered – operating current: passing value is 100 mA or less
5. Bus-powered – unconfigured current: passing value is 100 mA or less
6. Bus-powered – configured current: passing value is 500 mA or less
7. Bus-powered – suspend current: passing values are 500 μ A, 2.5 mA, 100 mA or less
8. Bus-powered – operating current: passing value is 500 mA or less

E Windows 98SE Peripheral Interoperability Testing

E.1 Equipment Used

Note that the equipment listed, the test procedure steps, and the actual list of required tests is expected to change. Please refer to <http://www.usb.org/developers/complian.html> on the USB-IF, Inc. web site for the latest version of this document.

item	description/model	qty
USB Host System	Hardware Configuration: TBD	1
average current draw test jig	[test fixtures acquired through USB-IF, Inc.]	1
Entrega Hub (Self-powered)	Hub4U	2
Imation SuperDisk(tm) Drive	Order Number 0-51122-40810-6	1
Intel Create and Share USB Camera	P/N 735147-001, Model#: CS330	1
KC Tech 1.1 Hub	WTC-6010S version 1.0	1
MS Internet Keyboard Pro (TI Hub)	Keyboard RT9420 V 5FTW	1
mouse	Logitech mouse P/N 830311-1000, Model#: M-BB48	8
Newnex Hub (Self-powered)	Model#: BT6AT01	1
one meter USB cables	any listed on USB-IF Cables and Connectors Integrators List	3
five meter USB cables	any listed on USB-IF Cables and Connectors Integrators List	6



Figure E-1: Average Current Draw Test Jig

E.2 Equipment Setup

E.2.1 Prepare the Host System

The host software required is Windows 98SE and the USBCheck tool. Either restore the saved image of the previously prepared system or follow the steps given in the following sections.

E.2.1.1 Install Windows 98SE

Use the default installation options: select 'typical' system configuration, install 'most common components', and select location 'US'.

Install any required platform-specific drivers – all devices should be 'working properly'; there should be no 'unknown devices' shown in the Windows 98SE Device Manager.

E.2.1.2 Install USBCheck

Run the USBComp.exe installation package from USB-IF, Inc. to install the USBCheck-related tools.

E.2.2 Initialize the Gold Tree

The Gold Tree devices are arranged:

- Hub 1 – Newnex Hub (Self-powered)
- Hub 2 – MS Internet Keyboard Pro (TI Hub) on port 1 of Newnex
- Logitech mouse on port 2 of MS Internet Keyboard Pro
- Hub 3 – Entrega Hub on port 3 of MS Internet Keyboard Pro
- Hub 4 – KC Tech Hub on port 1 of Hub 3 (Entrega Hub)
- Hub 5 – Entrega Hub on port 1 of KC Tech Hub
- Intel camera on port 1 of Hub 5 (Entrega Hub)
- Imation Superdisk on port 2 of Hub 5 (Entrega Hub)

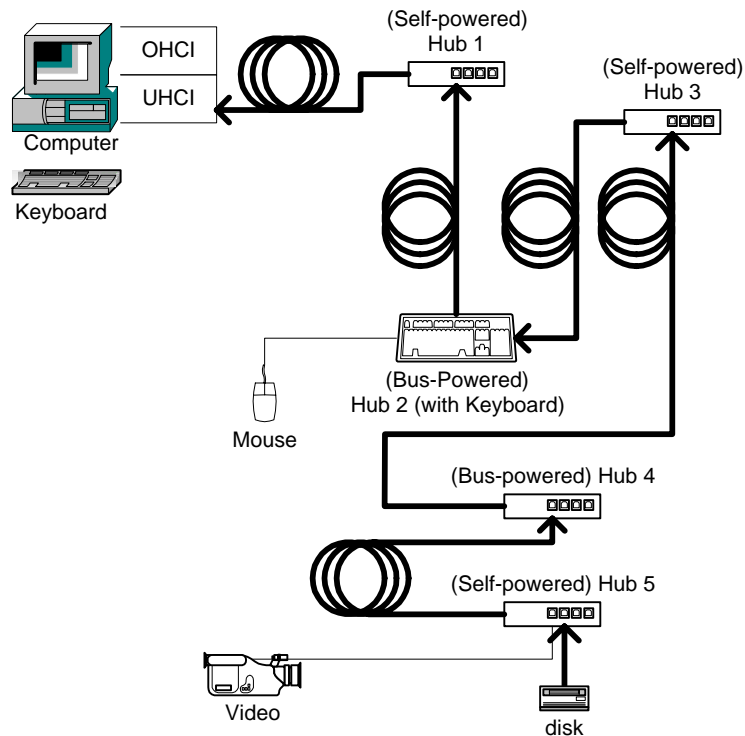

Figure E-2: Interoperability Gold Tree

Attach the Gold Tree to port #1 on the OHCI root hub. Verify that all the devices are operating properly by starting the appropriate applications: read data from the disk, show images from the video camera, type on the keyboard and move the mouse. Shut down all applications.

Unplug the Gold Tree from the OHCI root hub and connect the Gold Tree to port #1 on the UHCI root hub. Verify that all the devices are operating properly by starting the appropriate applications: read data

from the disk, show images from the video camera, type on the keyboard and move the mouse. Shut down all applications.

E.3 Test Steps

E.3.1 Non-Hub Devices

17. Plug in the device to the open port on Hub 5. Use a 5 meter cable if the device uses a removable cable.

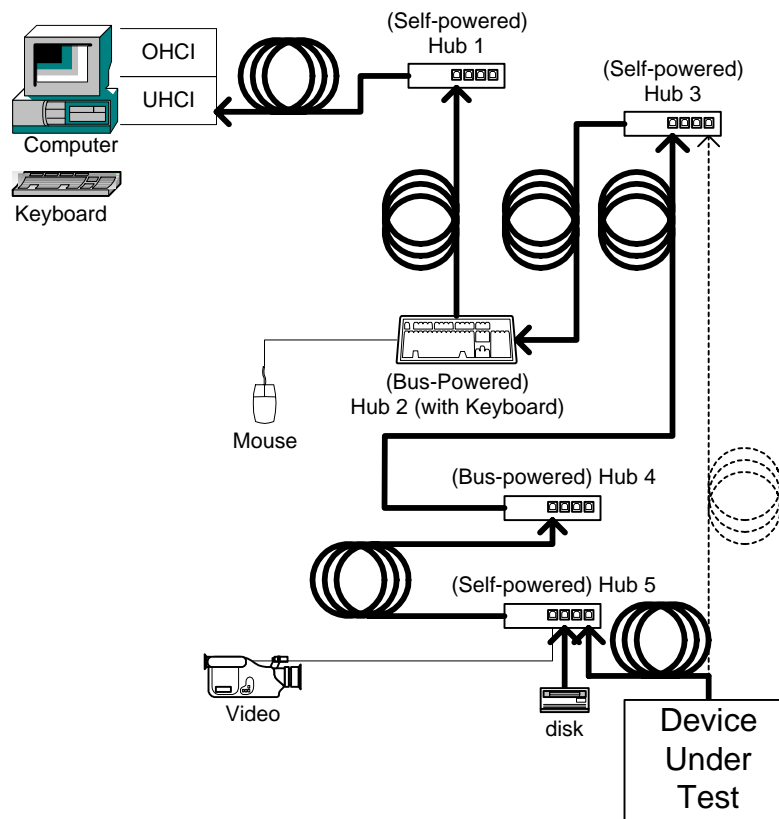

Figure E-3: Device Interoperability

18. Enumeration test

If the device is recognized by the OS use the support included in the GHOST image [Windows 98SE]. DO NOT install drivers from any vendor-supplied driver disk or CD at this time. Use only the drivers provided in the GHOST image for Device Interoperability Testing in this step.

If the OS indicates that it does not include support for this device, install the drivers provided on a vendor-supplied driver disk or CD now.

- Pass

- 1 Device enumerates with the 5 meter cable (if cable is not captive)
AND
- 2 Device enumerates below hub #5
AND
- 3 Driver installs with an .inf file (provided on a floppy or a CD) or is enumerated automatically by the system (class driver)
AND
- 4 Device under test does not require a reboot (except networking devices)
AND
- 5 Device under test is correctly identified by Device Manager

- Fail

- 1 Device under test requires driver installation or application software BEFORE device under test is plugged in
OR
- 2 Driver blue screens during enumeration
OR
- 3 Device under test requires reboot (and is not a networking device)
OR
- 4 Device under test is incorrectly identified by Device Manager
OR
- 5 Device under test does not enumerate below hub #5
OR
- 6 (If cable is not captive) Device cannot enumerate with 5 meter cable

19. Install any additional software

- Pass

- 1 Software installs without blue screens,
a) No reboot required
OR
b) Justification for reboot:
- 2 No software required

- Fail

- 1 Installation software blue screens / crashes system.

20. Device Under Test Demonstrates Operation Connected To Hub #5 with the 5 meter cable (if cable not captive).

- Pass
 - 1 Device operates as expected with the 5 meter cable (if cable not captive).

- Fail
 - 1 Device fails to operate
OR
 - 2 Device / application blue screens / crashes system
OR
 - 3 Device operates as expected but not when installed below Hub #5

21. Update Driver (if applicable)

If there is a vendor-supplied driver disk or CD

AND

the drivers installed in step 1 were part of the GHOST image (i.e. the drivers were not loaded from the vendor-supplied driver disk or CD), update the driver using Device Manager.

(else skip to step 7)

- Pass
 - 1 Driver is updated successfully with NO blue screens
AND
 - 2 No reboot is required unless device is a networking device
AND
 - 3 New driver is reported correctly in Device Manager

- Fail
 - 1 Any blue screen of death
OR
 - 2 Device under test requires reboot (and is not a networking device)
OR
 - 3 New driver is not reported correctly in Device Manager

22. Demonstrate operation with updated driver (if applicable)

- Pass
 - 1 Device operates as expected with the 5 meter cable (if cable not captive).

- Fail
 - 1 Device fails to operate
OR
 - 2 Device / application blue screens / crashes system
OR
 - 3 Device operates as expected but not when installed below Hub #5

23. Active Suspend

Stop! Disable the OHCI host controller using the device manager. [Windows 98SE]

– While device under test is in operation/use, suspend system. (Using keyboard, press windows button, start menu comes up, press, “u”, and then “return”.) System is placed in S3.

- Pass
 - 1 System suspends (Skip test #6)
OR
 - 2 System notifies user that the system cannot go into suspend (Go to test #6)
- Fail
 - 1 System blue screens / locks up

24. Inactive Suspend – No devices in use, suspend system by pressing sleep key on MS Internet Keyboard Pro keyboard (upper left corner). System is placed in S3.

- Pass
 - 1 System suspends
- Fail
 - 1 System blue screens / locks up
OR
 - 2 System fails to enter standby

25. Functionality after wakeup / resume – Check if device under test still operates.
- If device under test is a remote wakeup device, use it to wake up the system, otherwise use USB keyboard or mouse.
Test functionality of device under test.

- Pass
 - 1 If device under test is a remote wakeup device, device under test wakes up system
AND
 - 2 Device under test operates as in step #4

- Fail
 - 1 If device is a remote wakeup device and fails to wake up the system
OR
 - 2 Device under test fails to operate as in step #4

26. Switch Testing to OHCI

Stop! Enable the OHCI host controller using the device manager. [Windows 98SE]

- Disconnect gold tree from onboard UHCI controller
- Connect entire tree to OHCI root port #1
- Enumerate device under test below hub #5 with the 5-meter cable if cable not captive

- Pass
 - 1 Device enumerates with the 5 meter cable (if cable not captive)
AND
 - 2 Device enumerates below hub #5
AND
 - 3 Driver installs with an .inf file (provided on a floppy or a CD) or is enumerated automatically by the system (class driver)
AND
 - 4 Device under test does not require a reboot (except networking devices)
AND
 - 5 Device under test is correctly identified by Device Manager

- Fail
 - 1 Device under test requires driver installation or application software BEFORE device under test is plugged in
OR
 - 2 Driver blue screens during enumeration
OR
 - 3 Device under test requires reboot (and is not a networking device)
OR
 - 4 Device under test is incorrectly identified by Device Manager
OR
 - 5 Device under test does not enumerate below hub #5
OR

- 6 (If cable is not captive) Device cannot enumerate with 5 meter cable

27. Interoperability

Run each individual device in Gold Tree.

Check that device under test functions while other devices are operating.

- Pass

- 1 Device under test operates as in step #4
AND
- 2 Gold Tree devices all operate

- Fail

- 1 Device under test fails to operate as in step #4
OR
- 2 One or more Gold Tree devices fail to operate

28. Interoperability – Mouse Enumeration Test

While device under test is operating, camera is streaming, and mpeg/avi file is playing from mass storage device:

- Disconnect and reconnect Logitech mouse in same port in the MS Internet Keyboard Pro/hub
- Check that device under test functions while the gold tree devices are operating

- Pass

- 1 Device under test operates as in step #4
AND
- 2 Gold Tree devices all operate

- Fail

- 1 Device under test fails to operate as in step #4
OR
- 2 One or more Gold Tree devices fail to operate

29. Hot Detach & Reattach

Stop Device operation!

Detach and reattach device under test to same hub port.
Test functionality of device under test only.

- Pass
 - 1 Device under test operates as in step #4

- Fail
 - 1 Device under test fails to operate as in step #4

30. Topology Change

Stop Device operation!

Detach and reattach device under test to an open port on Hub #3.
Test functionality of device under test only.

- Pass
 - 1 Device under test operates as in step #4

- Fail
 - 1 Device under test fails to operate as in step #4

31. Warm boot

Restart system through the start menu (Start -> Shutdown -> Restart).
Test functionality of device under test after system reboots.

- Pass
 - 1 Device under test operates as in step #4

- Fail
 - 1 Device under test fails to operate as in step #4

32. Cold boot

Restart system through the start menu (Start -> Shutdown -> Shutdown).
Turn PC back on.
Test functionality of device under test after system reboots.

- Pass

1 Device under test operates as in step #4

- Fail

1 Device under test fails to operate as in step #4

E.3.2 Hubs

All hubs must pass the extended operability tests. Self-powered hubs must also pass the self-powered hub tests; bus-powered hubs must also pass the bus-powered hub tests. Hubs which operate in both bus- and self-powered modes must pass all three tests.

E.3.2.1 Self-Powered Hub Tests

4. Enumerate Hub

If hub under test has an embedded hub:

- Disconnect hub #4 from hub #3
- Connect hub under test to hub #3 with 5 meter cable.

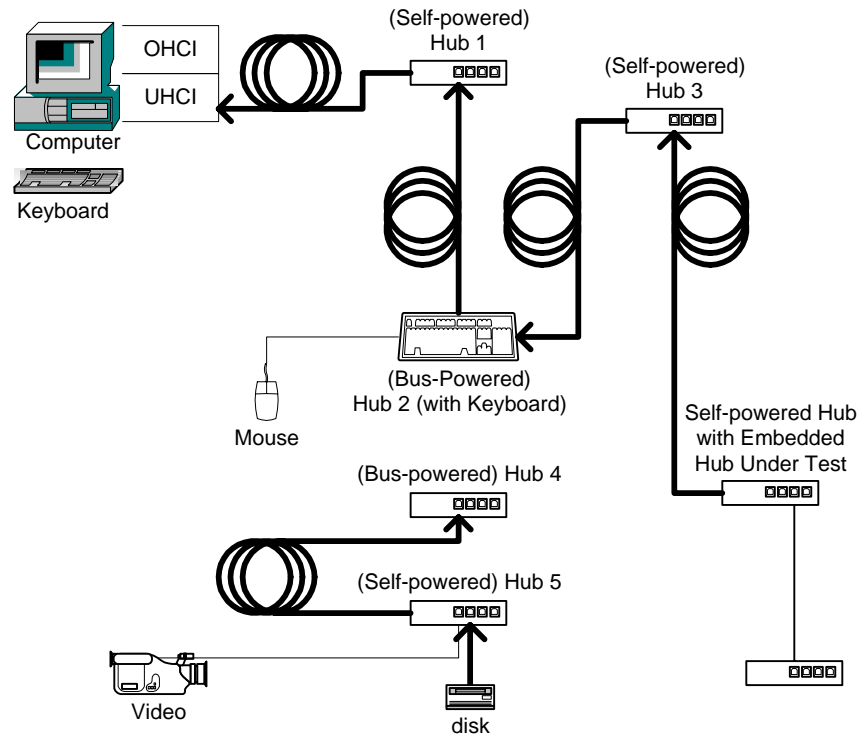

Figure E-4: Hub with Embedded Hub

Otherwise:

- Disconnect hub #5 from hub #4
- Connect hub under test to hub #4 with 5 meter cable.

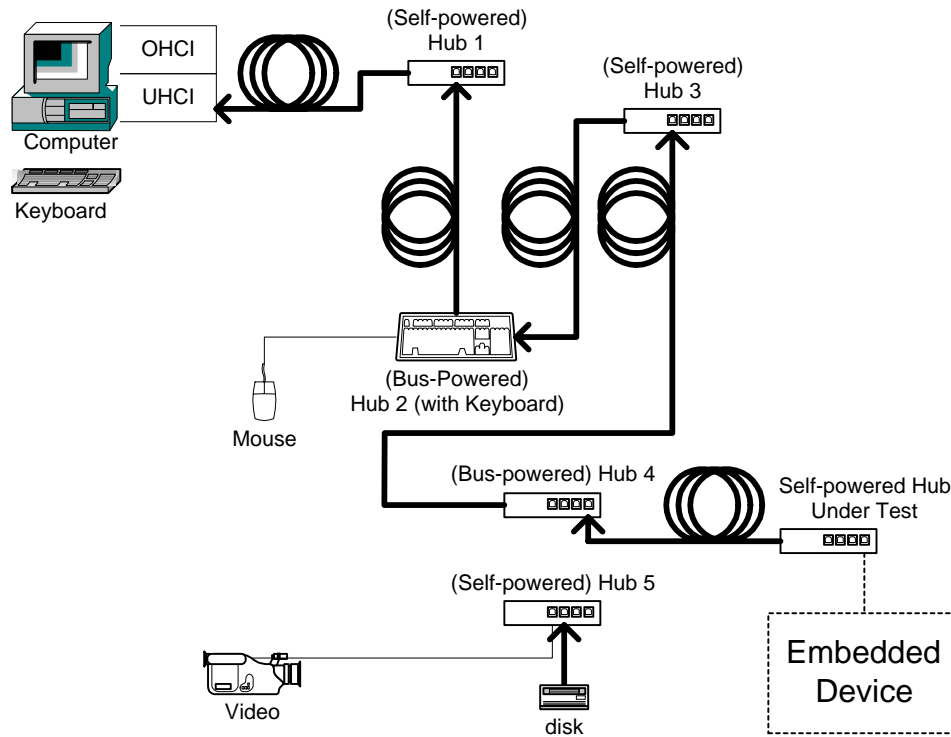

Figure E-5: Self-powered Hub Interoperability

- Pass
 - 1 Hub under test enumerates with the 5 meter cable
AND
 - 2 Hub under test enumerates below hub #3 if has embedded hub else hub #4
AND
 - 3 Hub under test does not require a reboot
AND
 - 4 Hub under test is correctly identified by Device Manager

- Fail
 - 1 Hub under test requires reboot (and is not a networking device)
OR
 - 2 Hub under test is incorrectly identified by Device Manager (for example, such as "Unknown Device" or "Other Device")
OR

- 3 Hub under test does not enumerate below hub #3 if hub has embedded hub else hub #4
OR
- 4 Hub cannot enumerate with 5 meter cable

7. Load driver and application for embedded function (if applicable).

- Pass

- 1 Driver and application software installs without blue screens (reboots allowed for application software, device if a networking device ONLY)
OR
- 2 No software required

- Fail

- 1 Installation software blue screens / crashes system
OR
- 2 Driver for embedded device requires reboot (except networking devices)

5. Test embedded function in Hub Under Test (if applicable)

- Pass

- 1 Embedded device operates as expected
OR
- 2 No embedded device

- Fail

- 1 Embedded device does not operate as expected OR
OR
- 2 Blue screen / locks up / system crash

8. Move devices that were connected to the disconnected Hub to the Hub Under Test

If hub under test has an embedded hub:

- move devices that were connected to hub #4 to first tier of hub under test
- move devices that were connected to hub #5 to embedded hub

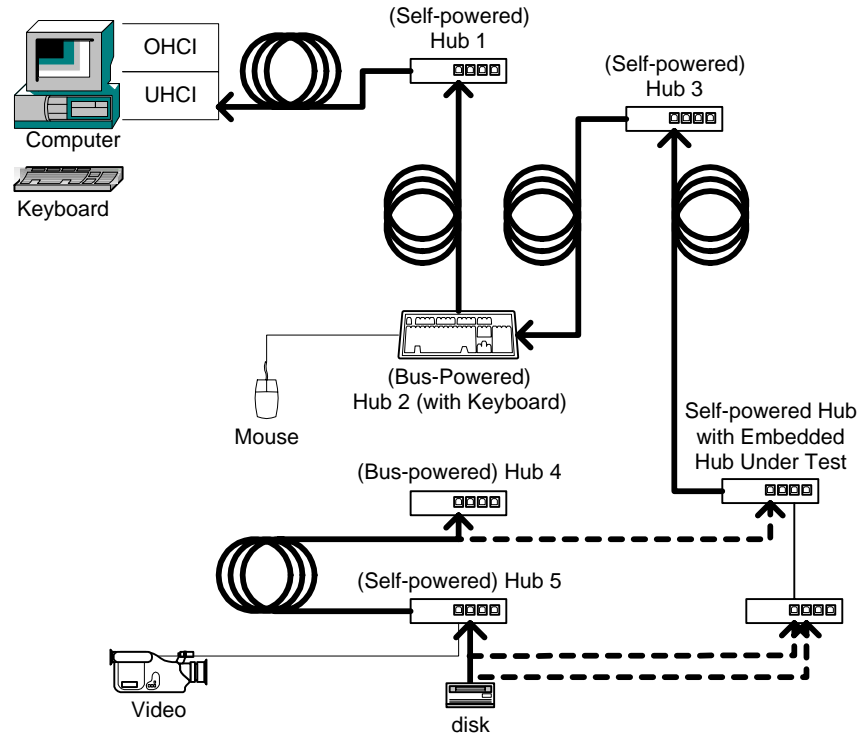

Figure E-6: Move Devices to Hub and Embedded Hub

Otherwise

- move devices that were connected to hub #5 to hub under test

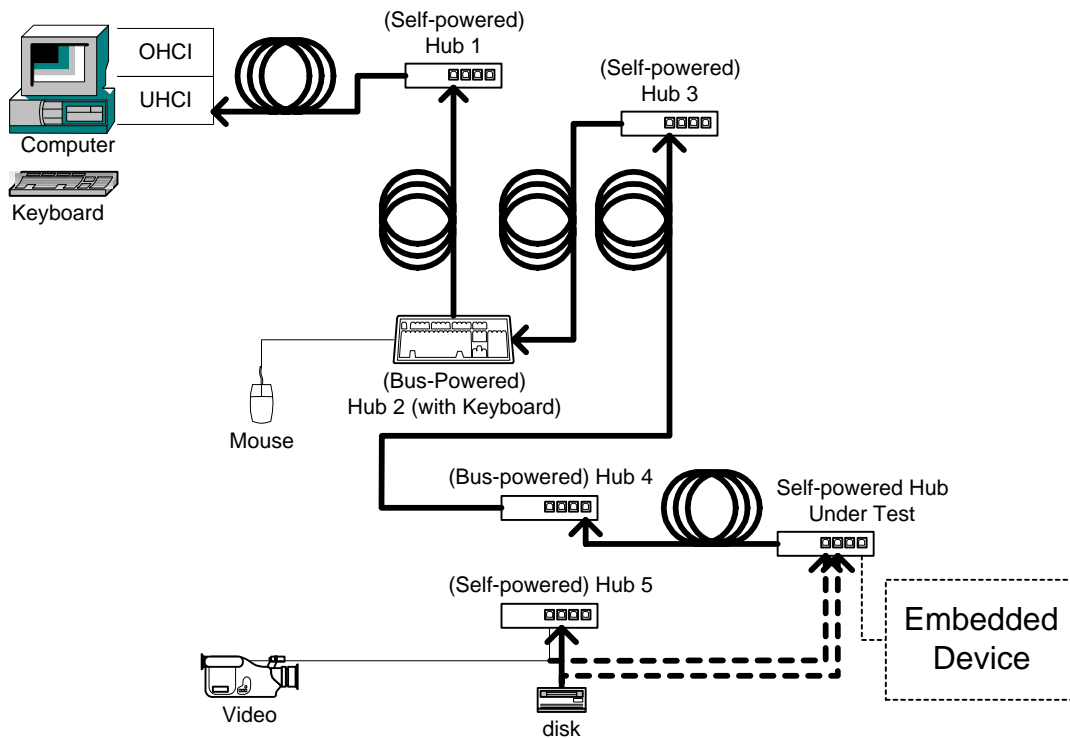

Figure E-7: Hub with Embedded Device (non-Hub)

- Pass
 - 1 Embedded device operates as expected
OR
 - 2 No embedded device
- Fail
 - 1 Embedded device does not operate as expected
OR
 - 2 Blue screen / locks up / system crash

9. Interoperability

- Test All Devices, including embedded device if applicable, simultaneously

- Pass

**For Review and Discussion Only
Draft Document Subject to Revision or Rejection
Not For Publication or General Distribution**

- 1 Every device operates as expected
- Fail
 - 1 One or more device does not operate as expected
OR
 - 2 Blue screen / locks up / system crash

E.3.2.2 Bus-Powered Hub Tests

4. Enumerate Hub

Connect with the 5 meter cable Hub Under Test To Hub #3

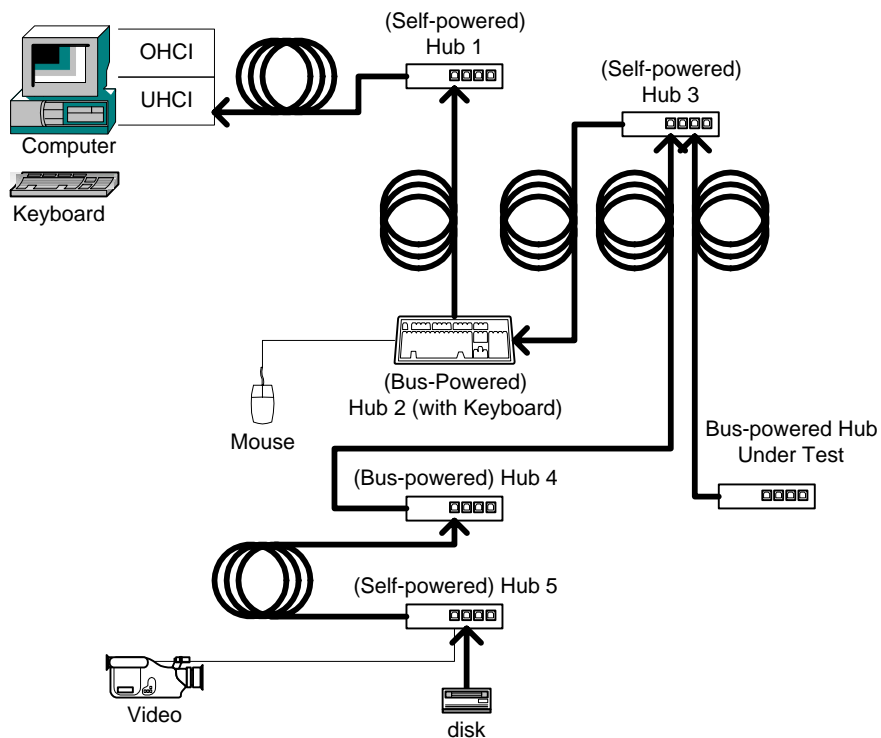

Figure E-8: Bus-powered Hub Interoperability

- Pass
 - 1 Hub under test enumerates with the 5 meter cable
AND
 - 2 Hub under test enumerates below hub #3
AND

- 3 Hub under test does not require a reboot
AND
- 4 Hub under test is correctly identified by Device Manager

- Fail

- 1 Hub under test requires reboot (and is not a networking device)
OR
- 2 Hub under test is incorrectly identified by Device Manager (for example, such as “Unknown Device” or “Other Device”)
OR
- 3 Hub under test does not enumerate below hub #3 if hub has embedded hub else hub #4
OR
- 4 Hub cannot enumerate with 5 meter cable

5. Load driver and application for embedded function (if applicable).

- Pass

- 1 Driver and application software installs without blue screens (reboots allowed for application software, device if a networking device ONLY)
OR
- 2 No software required

- Fail

- 1 Installation software blue screens / crashes system
OR
- 2 Driver for embedded device requires reboot (except networking devices)

6. Test embedded function in Hub Under Test (if applicable)

- Pass

- 1 Embedded device operates as expected
OR
- 2 No embedded device

- Fail

- 1 Embedded device does not operate as expected OR
OR
- 2 Blue screen / locks up / system crash

10. Move devices that were connected to the disconnected Hub, including the disconnected Hub to the Hub Under Test

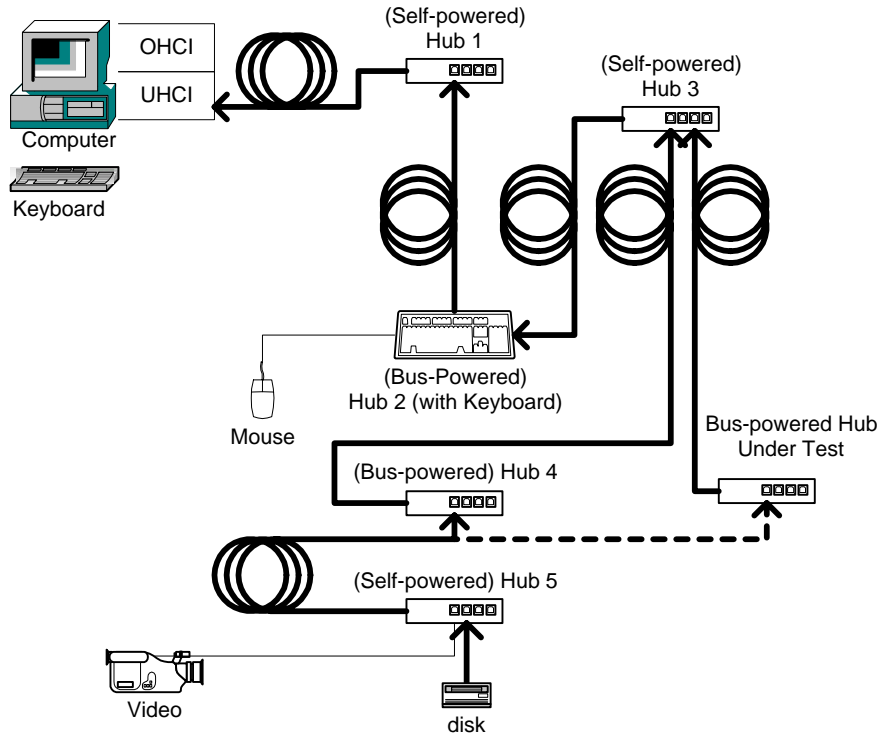

Figure E-9: Add Devices Below Hub Under Test

- Pass
 - 1 All devices enumerate properly
- Fail
 - 1 One or more device does not enumerate
OR
 - 2 Blue screen / locks up / system crash

6. Interoperability

- Test All Devices, including embedded device if applicable, simultaneously

- Pass

**For Review and Discussion Only
Draft Document Subject to Revision or Rejection
Not For Publication or General Distribution**

1 Every device operates as expected

- Fail

1 One or more device does not operate as expected
OR

2 Blue screen / locks up / system crash

E.3.2.3 Extended Operability Tests

7. Hot Detach and Reattach

Stop operation of any embedded device and all devices attached below hub under test!

- Detach and reattach hub under test to same hub port

- Pass

1 Every device operates as expected

- Fail

1 One or more device does not operate as expected
OR

2 Blue screen / locks up / system crash

8. Suspend

Stop! Disable the OHCI host controller using the device manager. [Windows 98SE]

- If hub has embedded function, while embedded function is in operation/use, suspend system by pressing sleep key on MS Internet Keyboard Pro keyboard (upper left corner).

- If embedded function prevents suspend, stop operation of embedded function and repeat previous step.

- Pass

1 System suspends

- Fail

- 1 System cannot enter suspend (even when embedded function is inactive)
OR
- 2 System blue screens / locks up

9. System Resume

- Use embedded function to wakeup system if a wakeup device
- Test all devices after resume

- Pass

- 1 System resumes
AND
- 2 All devices operate correctly

- Fail

- 1 One or more device fails to operate correctly
OR
- 2 System fails to resume

10. Connect to OHCI

Stop! Enable the OHCI host controller using the device manager. [Windows 98SE]

- Test all devices after connection of the tree to the OHCI root hub.

- Pass

- 1 All devices enumerate
AND
- 2 All devices operate correctly

- Fail

- 1 One or more device fails to enumerate
OR
- 2 One or more device fails to operate correctly

11. Warm Boot

Restart system through the start menu (Start -> Shutdown -> Restart).
Test functionality of all devices after system reboots.

- Pass

- 1 All devices operate correctly
- Fail
 - 1 One or more device fails to operate correctly
OR
 - 2 System fails to reboot

12. Cold Boot

Restart system through the start menu (Start -> Shutdown -> Shutdown).
Turn PC back on.
Test functionality of all devices after system reboots.

- Pass
 - 1 All devices operate correctly
- Fail
 - 1 One or more device fails to operate correctly
OR
 - 2 System fails to reboot

E.3.3 Measuring Average Current Draw

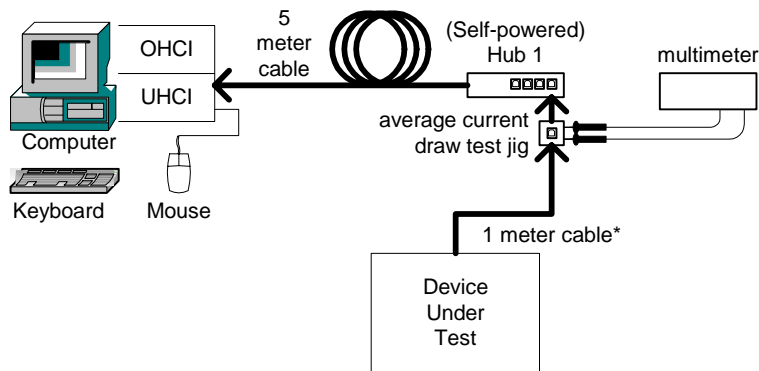

Figure E-10: Average Current Measurement

- 5. Measure current in Address state (not configured)
 - start USBCheck/Chap9
 - plug the Device or Hub under test into the average current draw test jig

**For Review and Discussion Only
Draft Document Subject to Revision or Rejection
Not For Publication or General Distribution**

- verify that the device is operating by reading its descriptors
- record the average current shown on the multimeter as 'not configured current'

- Pass

- 1 measured current is 100 mA or less

- Fail

- 1 measured current exceeds 100 mA

6. Measure current in Configured state

- exit USBCheck
- unplug and replug the Device or Hub under test into the average current draw test jig
- verify that the device enumerates and is correctly identified by Device Manager
- record the average current shown on the multimeter as 'configured current'

- Pass

- 1 measured current is less than the value recorded during device framework testing

- Fail

- 1 measured current exceeds the value recorded during device framework testing

7. Measure current under normal operation

- use the device, verify that it is operating normally
- record the average current shown on the multimeter as 'operating current'

- Pass

- 1 measured current is less than the value recorded during device framework testing

- Fail

- 1 measured current exceeds the value recorded during device framework testing

8. Measure current when device is suspended

Stop! Disable the OHCI host controller using the device manager. [Windows 98SE]

- suspend system by pressing sleep key on MS Internet Keyboard Pro keyboard (upper left corner).
- If embedded function prevents suspend, stop operation of embedded function and repeat previous step.
- record the average current shown on the multimeter as 'suspend current'

- Pass

- 1 measured current is 500 μ A or less
OR
- 2 device is configured for high-power
AND device is enabled as a remote wakeup device
AND measured current is 2.5 mA or less

- Fail

- 1 measured current exceeds 500 μ A AND device is configured for operation with low-power
OR
- 2 measured current exceeds 2.5 mA

E.4 Reporting Results

E.4.1 Interoperability Results

Non Hub Test Results

8. Enumerate Device: PASS/FAIL
9. Install Additional Software PASS/FAIL
10. DUT Demonstrates Operation PASS/FAIL
11. Active Suspend: PASS/FAIL/not supported
12. InActive Suspend: PASS/FAIL/NA
13. Functionality After WakeUp-Resume: PASS/FAIL
14. Switch Testing to OHCI: PASS/FAIL

Interoperability

6. Interoperability - Mouse Enumeration Test: PASS/FAIL
7. Hot Attach & Reattach: PASS/FAIL

- 8. Topology Change: PASS/FAIL
- 9. Warm Reboot: PASS/FAIL
- 10. Cold Reboot: PASS/FAIL

OVERALL HUB RESULTS

Self-powered Hub Results: PASS/FAIL/NA
Self-powered-Enumerate Hub: PASS/FAIL/NA

Self-powered-Load Driver & Application: PASS/FAIL/NA

Self-powered-Test Embedded function in HUT: PASS/FAIL/NA

Self-powered-Move Device: PASS/FAIL/NA

Self-powered-Interoperability: PASS/FAIL/NA

Bus-powered Hub Results: PASS/FAIL/NA

Bus-powered-Enumerate Hub: PASS/FAIL/NA

Bus-powered-Load Driver & Application: PASS/FAIL/NA

Bus-powered-Test Embedded function in HUT: PASS/FAIL/NA

Bus-powered-Move Device: PASS/FAIL/NA

Bus-powered-Interoperability: PASS/FAIL/NA

Extended Operability Test Results: PASS/FAIL/NA

Ex-Hot Detach and Reattach: PASS/FAIL/NA

Ex-Suspend: PASS/FAIL/NA

Ex-System Resume: PASS/FAIL/NA

Ex-Warm Reboot: PASS/FAIL/NA

Ex-Cold Reboot: PASS/FAIL/NA

Interoperability Comments: [text]

E.4.2 Current Measurement Results

9. Self-powered – unconfigured current: passing value is 100 mA or less
10. Self-powered – configured current: passing value is 100 mA or less
11. Self-powered – suspend current: passing values are 500 μ A or less
12. Self-powered – operating current: passing value is 100 mA or less
13. Bus-powered – unconfigured current: passing value is 100 mA or less
14. Bus-powered – configured current: passing value is 500 mA or less
15. Bus-powered – suspend current: passing values are 500 μ A, 2.5 mA, 100 mA or less
16. Bus-powered – operating current: passing value is 500 mA or less

F Windows 98SE Host Interoperability Testing

Host interoperability testing applies to add-in cards, motherboards, and systems that are used with full speed and low speed USB devices and hubs.

F.1 Equipment Used

Note that the equipment listed, the test procedure steps, and the actual list of required tests is expected to change. Please refer to <http://www.usb.org/developers/complian.html> on the USB-IF, Inc. web site for the latest version of this document.

item	description/model	qty
USB Host System	(used only when testing a host controller add-in card) Hardware Configuration: TBD	1
Entrega Hub (Self-powered)	Hub4U	2
Imation SuperDisk(tm) Drive	Order Number 0-51122-40810-6	1
Intel Create and Share USB Camera	P/N 735147-001, Model#: CS330	1
KC Tech 1.1 Hub	WTC-6010S version 1.0	1
MS Internet Keyboard Pro (TI Hub)	Keyboard RT9420 V 5FTW	1
mouse	Logitech mouse P/N 830311-1000, Model#: M-BB48	8
Newnex Hub (Self-powered)	Model#: BT6AT01	1
five meter USB cables	any listed on USB-IF Cables and Connectors Integrators List	6

F.2 Prepare the Host System

The host software required is Windows 98SE and various vendor-specific drivers. Either restore the saved image of the previously prepared system or follow the steps given in the following sections.

F.2.1.1 Install Windows 98SE

Use the default installation options: select 'typical' system configuration, install 'most common components', and select location 'US'.

Install any required platform-specific drivers – all devices should be 'working properly'; there should be no 'unknown devices' shown in the Windows 98SE Device Manager.

F.2.1.2 Initialize Gold Tree

The Gold Tree devices are arranged:

- Hub 1 – Newnex Hub (Self-powered)
- Hub 2 – MS Internet Keyboard Pro (TI Hub) on port 1 of Newnex
- Logitech mouse on port 2 of MS Internet Keyboard Pro
- Hub 3 – Entrega Hub on port 3 of MS Internet Keyboard Pro
- Hub 4 – KC Tech Hub on port 1 of Hub 3 (Entrega Hub)
- Hub 5 – Entrega Hub on port 1 of KC Tech Hub
- Intel camera on port 1 of Hub 5 (Entrega Hub)
- Imation Superdisk on port 2 of Hub 5 (Entrega Hub)

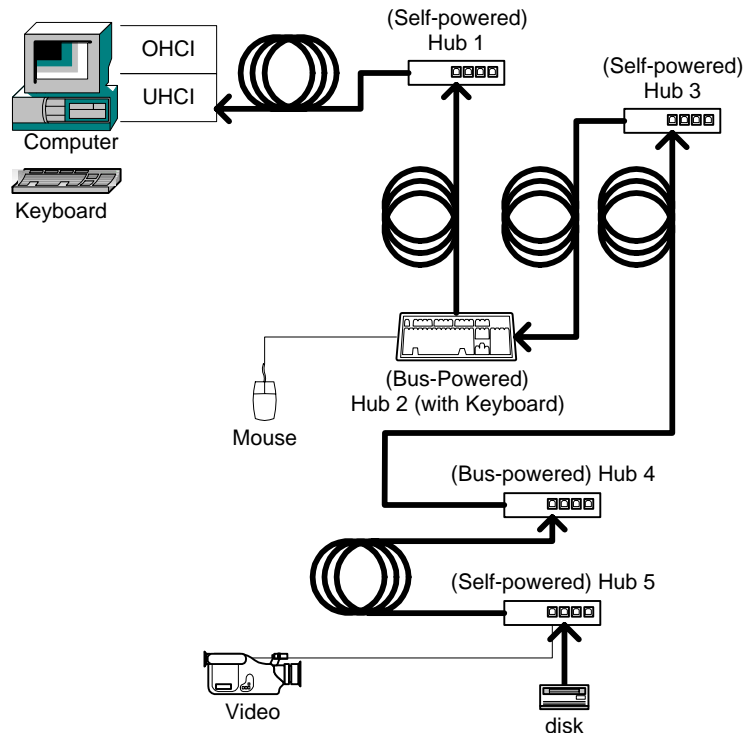

Figure F-1: Windows 98SE Interoperability Gold Tree

Attach the Gold Tree to port #1 on the host system under test. Verify that all the devices are operating properly by starting the appropriate applications: read data from the disk, show images from the video camera, type on the keyboard and move the mouse. Shut down all applications.

F.3 Test Steps

1. Boot system with USB host controllers installed and Gold Tree devices attached.

- Pass

- 1 Host controller enumerates
AND
- 2 Driver loaded
AND
- 3 Host Controller correctly identified by Device Manager
AND
- 4 All devices enumerate
AND
- 5 All devices correctly identified by Device Manager

- Fail

- 1 Blue Screen
OR
- 2 System Hang
OR
- 3 Host Controller or one or more devices incorrectly identified by Device Manager

2. Demonstrate Operation of Gold Tree

- Pass

- 1 All devices function as expected

- Fail

- 1 Any devices fails to function as expected
OR
- 2 Blue Screen, System Hang or System Crash

3. If System does not support ACPI S1 and S3 States go to step 9, "Generic" Suspend.

S1 – Suspend System to ACPI State S1

Configure System to Suspend to S1 via BIOS setting and Suspend system.

- Pass

- 1 System Suspends

- Fail

- 1 System Fails to Suspend
OR
- 2 Blue Screen, System Hang or System Crash

4. S1 – Wakeup System from ACPI State S1
Click on USB mouse or USB keyboard to wake up system

- Pass

- 1 System Wakes Up

- Fail

- 1 System Fails to Wake Up
OR
- 2 Blue Screen, System Hang or System Crash

5. Device Functionality After Resume from S1
Run each device in Gold Tree simultaneously.

- Pass

- 1 All devices function as expected

- Fail

- 1 Any devices fails to function as expected
OR
- 2 Blue Screen, System Hang or System Crash

6. S3 – Suspend System to ACPI State S3
Configure System to Suspend to S3 via BIOS setting and Suspend system.

- Pass

- 1 System Suspends

- Fail

- 1 System Fails to Suspend
OR
- 2 Blue Screen, System Hang or System Crash

7. S3 – Wakeup System from ACPI State S3

- If the host controller under test is integrated or is the only host controller present in the system under test, Click on USB mouse or USB keyboard to wake up system
- Otherwise (add-in card), Click on PS/2 mouse or PS/2 keyboard to wake up system. Note that USB is powered off in S3 in this case.

- Pass

- 1 System Wakes Up

- Fail

- 1 System Fails to Wake Up
OR
- 2 Blue Screen, System Hang or System Crash

8. Device Functionality After Resume from S3
Run each device in Gold Tree simultaneously.

- Pass

- 1 All devices function as expected

- Fail

- 1 Any devices fails to function as expected
OR
- 2 Blue Screen, System Hang or System Crash

Go to Step 12, Warm Boot – do not run “Generic” Suspend test sequence after completing ACPI S1 and S3 State test sequence.

9. “Generic” Suspend – Use this process only if the System does not indicate that it supports ACPI S1 and S3 States.

Configure System to Suspend and Suspend system.

- Pass

- 1 System Suspends

- Fail

- 1 System Fails to Suspend
OR
- 2 Blue Screen, System Hang or System Crash

10. Wakeup System from “Generic” Suspend

Click on USB mouse or USB keyboard to wake up system

- Pass

- 1 System Wakes Up

- Fail

- 1 System Fails to Wake Up
OR
- 2 Blue Screen, System Hang or System Crash

11. Device Functionality after Resume from “Generic” Suspend

Run each device in Gold Tree simultaneously.

- Pass

- 1 All devices function as expected

- Fail

- 1 Any devices fails to function as expected
OR
- 2 Blue Screen, System Hang or System Crash

12. Warm Boot

Reboot system via Start Menu (Start -> Shutdown ->Restart). Test all devices working after reboot.

- Pass

1 All devices function as expected

- Fail

1 Any devices fails to function as expected
OR

2 Blue Screen, System Hang or System Crash

13. Cold Boot

Reboot system via Start Menu (Start -> Shutdown ->Shutdown. Turn PC back on). Test all devices working after reboot.

- Pass

1 All devices function as expected

- Fail

1 Any devices fails to function as expected
OR

2 Blue Screen, System Hang or System Crash

14. Gold Device Interoperability Test

Perform the full device (non-hub) USB-IF interoperability test for a known good device using the host controller under test as the root host controller.

- Pass

1 The known good device passes all interoperability tests

- Fail

1 The known good device fails any part of the interoperability tests

15. Gold Hub Interoperability Test

Perform the full hub USB-IF interoperability test for a known good hub using the host controller under test as the root host controller.

- Pass

1 The known good hub passes all interoperability tests

- Fail

- 1 The known good hub fails any part of the interoperability tests

G Windows 2000 Host Interoperability Testing

G.1 Equipment Used

Note that the equipment listed, the test procedure steps, and the actual list of required tests is expected to change. Please refer to <http://www.usb.org/developers/complian.html> on the USB-IF, Inc. web site for the latest version of this document.

item	description/model	qty
USB Host System	(used only when testing a host controller add-in card) Hardware Configuration: TBD	1
Entrega Hub (Self-powered)	Hub4U	2
Imation SuperDisk(tm) Drive	Order Number 0-51122-40810-6	1
Intel Create and Share USB Camera	P/N 735147-001, Model#: CS330	1
KC Tech 1.1 Hub	WTC-6010S version 1.0	1
MS Internet Keyboard Pro (TI Hub)	Keyboard RT9420 V 5FTW	1
mouse	Logitech mouse P/N 830311-1000, Model#: M-BB48	8
Newnex Hub (Self-powered)	Model#: BT6AT01	1
five meter USB cables	any listed on USB-IF Cables and Connectors Integrators List	6

G.2 Prepare the Host System

The host software required is Windows 2000 Professional and the USBCheck tool. Either restore the saved image of the previously prepared system or follow the steps given in the following sections.

G.2.1.1 Install Windows 2000 Professional

Use the default installation options: select 'typical' system configuration, install 'most common components', and select location 'US'.

Install any required platform-specific drivers – all devices should be 'working properly'; there should be no 'unknown devices' shown in the Windows 2000 Device Manager.

G.2.1.2 Initialize Gold Tree

The Gold Tree devices are arranged:

- Hub 1 – Newnex Hub (Self-powered)
- Hub 2 – MS Internet Keyboard Pro (TI Hub) on port 1 of Newnex
- Logitech mouse on port 2 of MS Internet Keyboard Pro
- Hub 3 – Entrega Hub on port 3 of MS Internet Keyboard Pro
- Hub 4 – KC Tech Hub on port 1 of Hub 3 (Entrega Hub)
- Hub 5 – Entrega Hub on port 1 of KC Tech Hub
- Intel camera on port 1 of Hub 5 (Entrega Hub)
- Imation Superdisk on port 2 of Hub 5 (Entrega Hub)

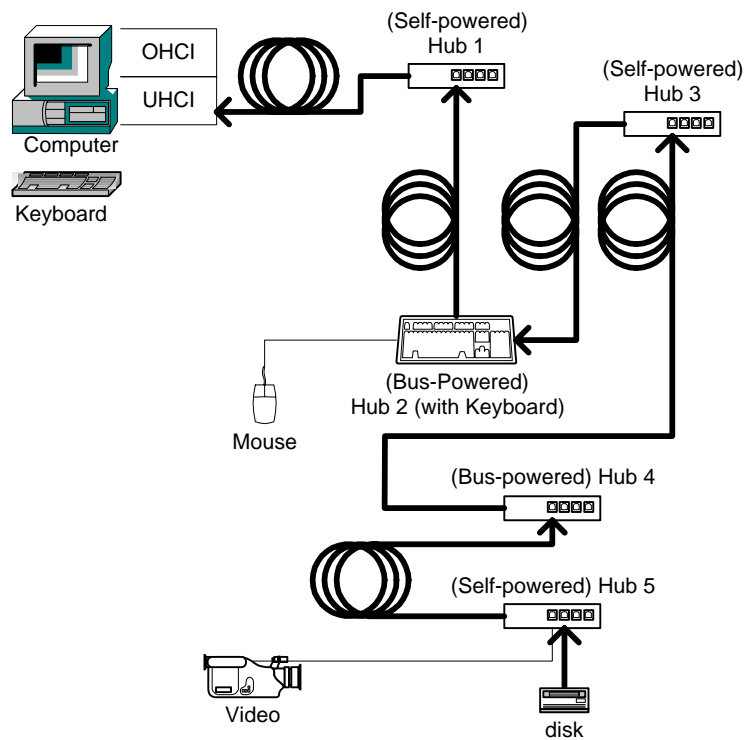

Figure G-1: Windows 2000 Interoperability Gold Tree

Attach the Gold Tree to port #1 on the host system under test. Verify that all the devices are operating properly by starting the appropriate applications: read data from the disk, show images from the video camera, type on the keyboard and move the mouse. Shut down all applications.

G.3 Test Steps

1. Boot system with USB host controllers installed and Gold Tree devices attached.
 - Pass

- 1 Host controller enumerates
AND
- 2 Driver loaded
AND
- 3 Host Controller correctly identified by Device Manager
AND
- 4 All devices enumerate
AND
- 5 All devices correctly identified by Device Manager

- Fail

- 1 Blue Screen
OR
- 2 System Hang
OR
- 3 Host Controller or one or more devices incorrectly identified by Device Manager

2. Demonstrate Operation of Gold Tree

- Pass

- 1 All devices function as expected

- Fail

- 1 Any devices fails to function as expected
OR
- 2 Blue Screen, System Hang or System Crash

3. If System does not support ACPI S1 and S3 States go to step 9, "Generic" Suspend.

S1 – Suspend System to ACPI State S1

Configure System to Suspend to S1 via BIOS setting and Suspend system.

- Pass

- 1 System Suspends

- Fail

- 1 System Fails to Suspend
OR

2 Blue Screen, System Hang or System Crash

4. S1 – Wakeup System from ACPI State S1

Click on USB mouse or USB keyboard to wake up system

- Pass

1 System Wakes Up

- Fail

1 System Fails to Wake Up
OR

2 Blue Screen, System Hang or System Crash

5. Device Functionality After Resume from S1

Run each device in Gold Tree simultaneously.

- Pass

1 All devices function as expected

- Fail

1 Any devices fails to function as expected
OR

2 Blue Screen, System Hang or System Crash

6. S3 – Suspend System to ACPI State S3

Configure System to Suspend to S3 via BIOS setting and Suspend system.

- Pass

1 System Suspends

- Fail

1 System Fails to Suspend
OR

2 Blue Screen, System Hang or System Crash

7. S3 – Wakeup System from ACPI State S3

- If the host controller under test is integrated or is the only host controller present in the system under test, Click on USB mouse or USB keyboard to wake up system
- Otherwise (add-in card), Click on PS/2 mouse or PS/2 keyboard to wake up system. Note that USB is powered off in S3 in this case.

- Pass

- 1 System Wakes Up

- Fail

- 1 System Fails to Wake Up
OR
 - 2 Blue Screen, System Hang or System Crash

8. Device Functionality After Resume from S3

Run each device in Gold Tree simultaneously.

- Pass

- 1 All devices function as expected

- Fail

- 1 Any devices fails to function as expected
OR
 - 2 Blue Screen, System Hang or System Crash

Go to Step 12, Warm Boot – do not run “Generic” Suspend test sequence after completing ACPI S1 and S3 State test sequence.

9. “Generic” Suspend – Use this process only if the System does not indicate that it supports ACPI S1 and S3 States.

Configure System to Suspend and Suspend system.

- Pass

- 1 System Suspends

- Fail

- 1 System Fails to Suspend
OR
- 2 Blue Screen, System Hang or System Crash

10. Wakeup System from “Generic” Suspend

Click on USB mouse or USB keyboard to wake up system

- Pass

- 1 System Wakes Up

- Fail

- 1 System Fails to Wake Up
OR
- 2 Blue Screen, System Hang or System Crash

11. Device Functionality after Resume from “Generic” Suspend

Run each device in Gold Tree simultaneously.

- Pass

- 1 All devices function as expected

- Fail

- 1 Any devices fails to function as expected
OR
- 2 Blue Screen, System Hang or System Crash

12. Warm Boot

Reboot system via Start Menu (Start -> Shutdown ->Restart). Test all devices working after reboot.

- Pass

- 1 All devices function as expected

- Fail

- 1 Any devices fails to function as expected
OR

- 2 Blue Screen, System Hang or System Crash

13. Cold Boot

Reboot system via Start Menu (Start -> Shutdown ->Shutdown. Turn PC back on). Test all devices working after reboot.

- Pass

- 1 All devices function as expected

- Fail

- 1 Any devices fails to function as expected
OR
- 2 Blue Screen, System Hang or System Crash

14. Gold Device Interoperability Test

Perform the full device (non-hub) USB-IF interoperability test for a known good device using the host controller under test as the root host controller.

- Pass

- 1 The known good device passes all interoperability tests

- Fail

- 1 The known good device fails any part of the interoperability tests

15. Gold Hub Interoperability Test

Perform the full hub USB-IF interoperability test for a known good hub using the host controller under test as the root host controller.

- Pass

- 1 The known good hub passes all interoperability tests

- Fail

- 1 The known good hub fails any part of the interoperability tests