

## USB 3.0 Electrical Test Fixture Topologies:

For more information please contact your test equipment vendor or see the Electrical Compliance Specification located at: <http://www.usb.org/developers/ssusb/testing>

### RX Calibration Topologies:

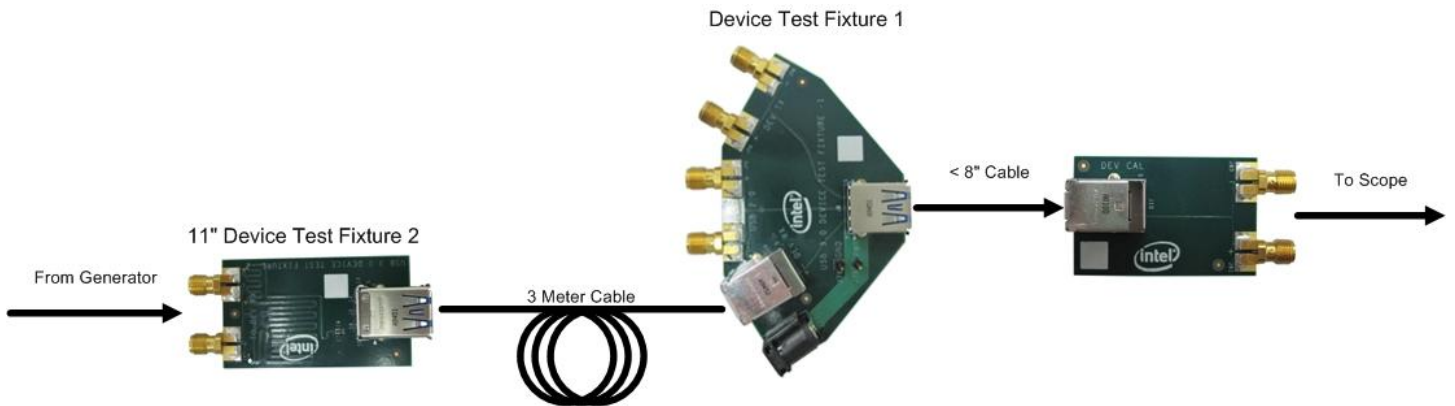

Figure 1: Device Rx Calibration Topology

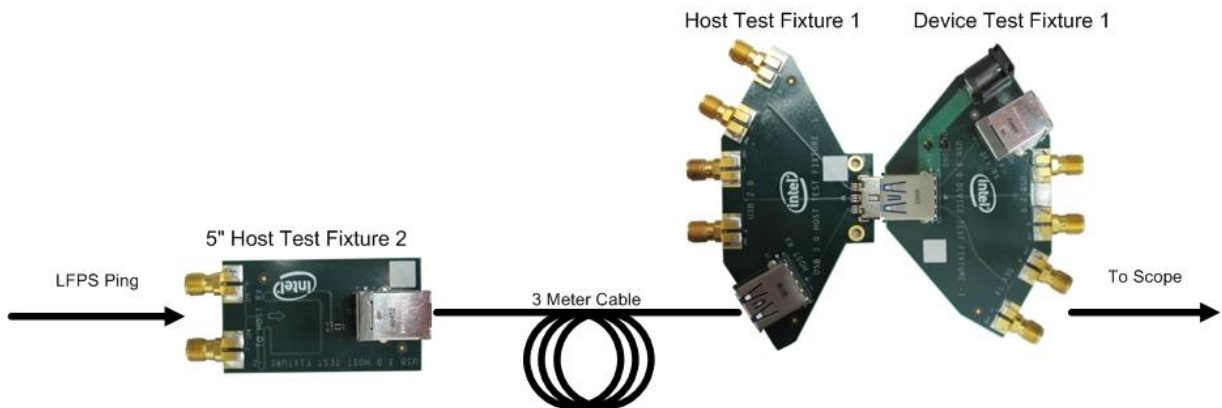

Figure 2: Host Rx Calibration Topology

## RX Test Topologies:

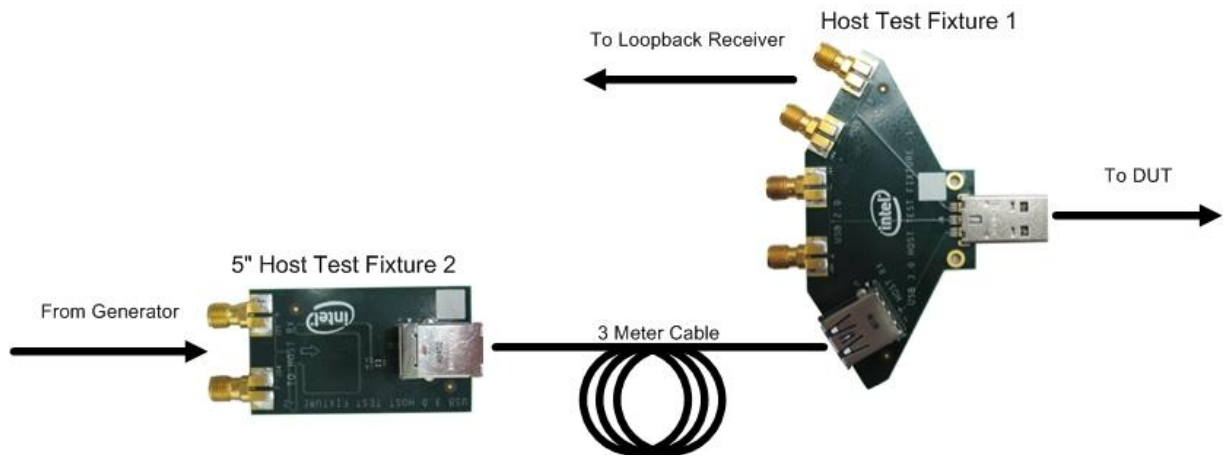

Figure 3: Host Rx Test Topology

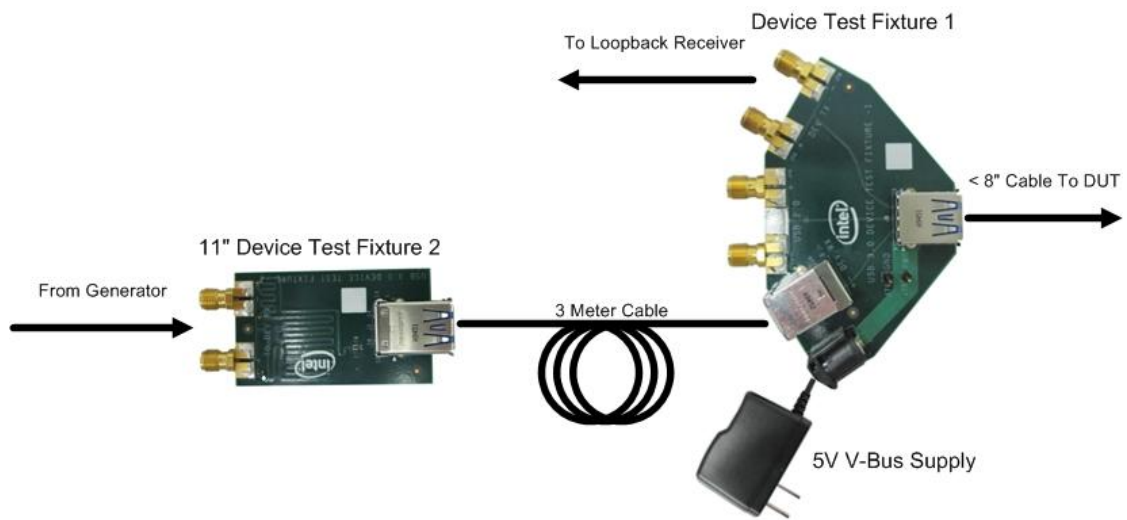

Figure 4: Device Rx Test Topology

## Tx Test Topologies:

Note: Tx testing requires software-based channel emulation.

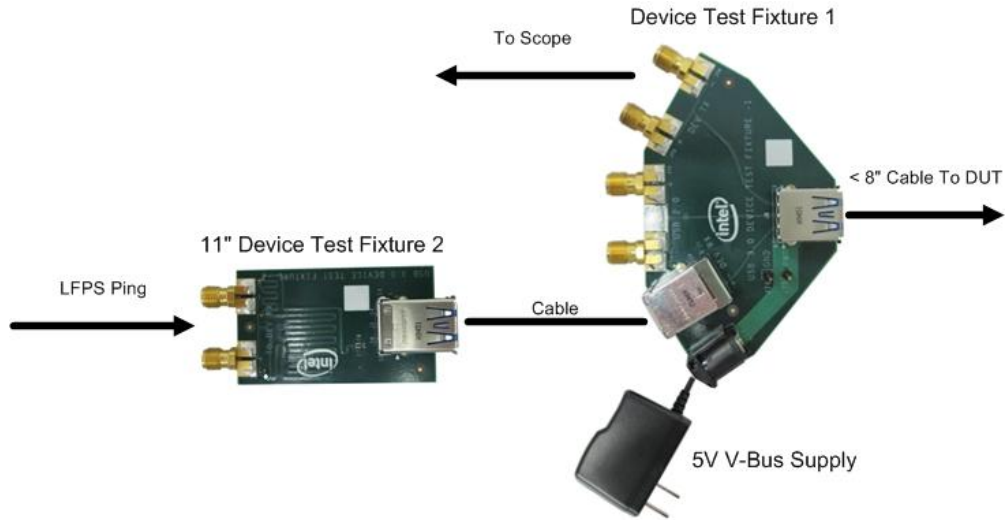

Figure 5: Device Tx Test Topology

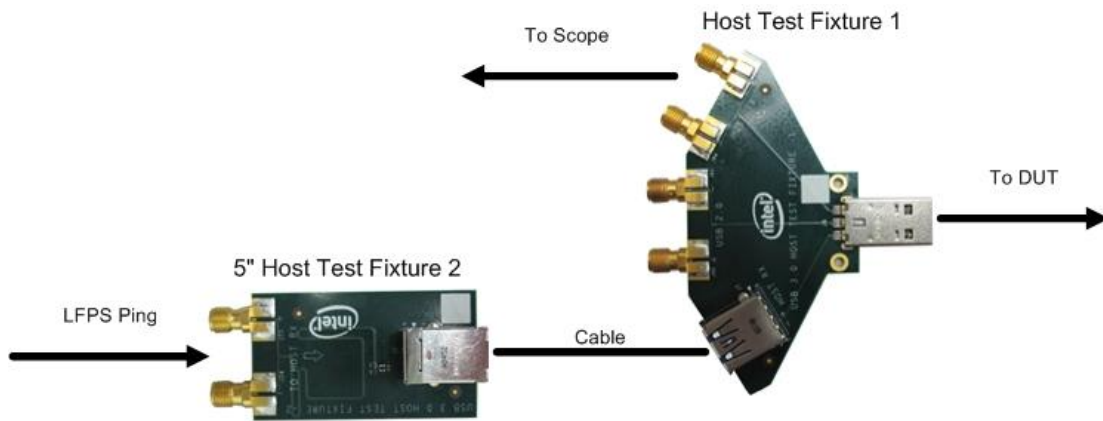

Figure 6: Host Tx Test Topology