



Certified Wireless USB Wire Adapter Model

Abdul R. Ismail

Intel Corporation

*Content also provided by:
Matt Katagiri, NEC*

Agenda



- Overview
- Software-Hardware Overview
- Data Delivery Mechanism: RPipe
- Hardware Architecture
- Wire Adapter Device Class
- Software Architecture
- Summary

Purpose of Wire Adapter



- To provide a USB-to-Wireless USB bridge
 - Host side wireless extension
- To easily convert wired USB devices to wireless
 - Device side wireless extension
- To be an enabler of Certified Wireless USB technology and inherit the popularity of the most successful interface in the world

Two Types of Wire Adapter

Host Wire Adapter and Device Wire Adapter

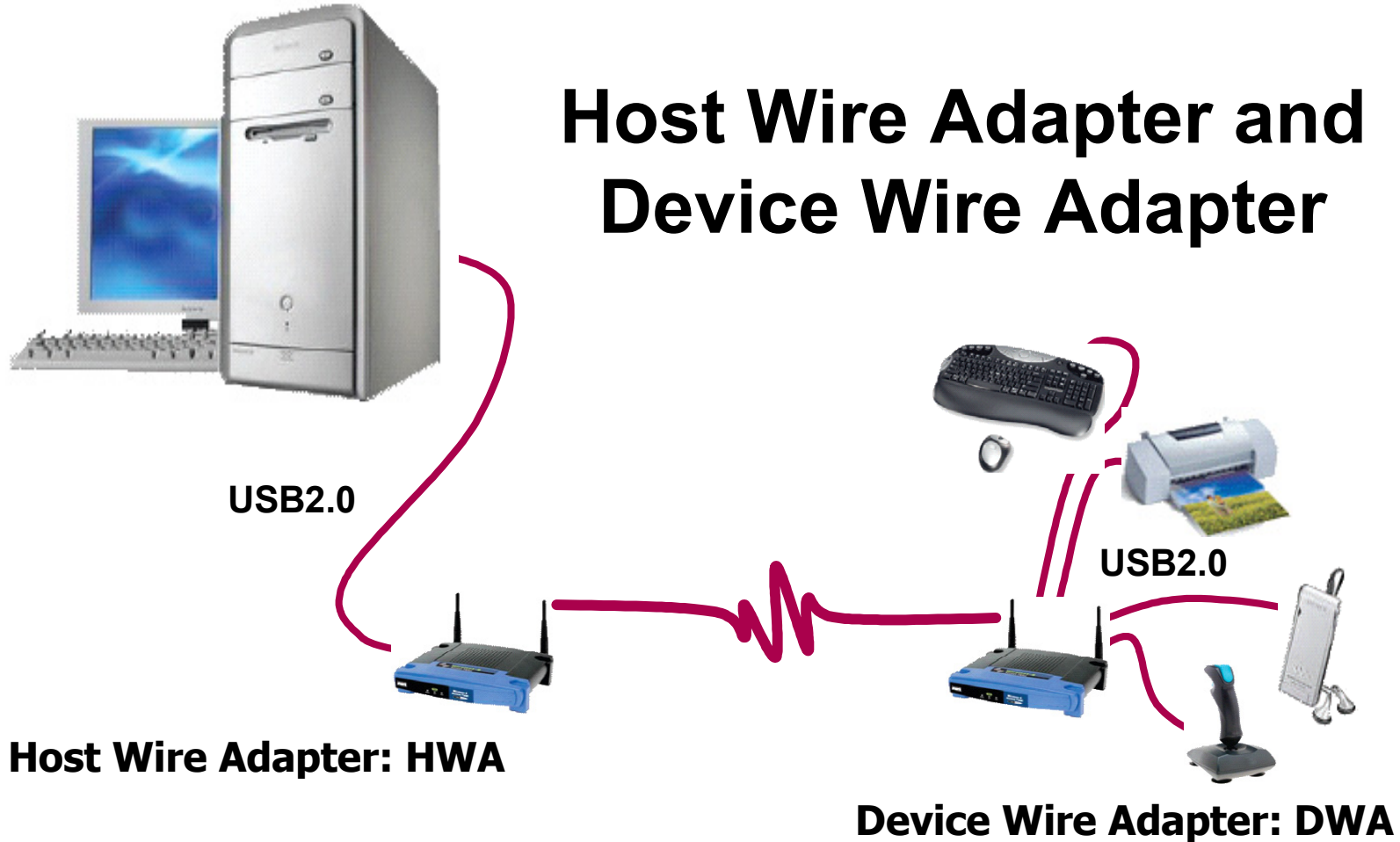

Agenda



- Overview
- **Software-Hardware Overview**
- Data Delivery Mechanism: RPipe
- Hardware Architecture
- Software-Hardware Interface
- Wire Adapter Device Class
- Summary

Topology

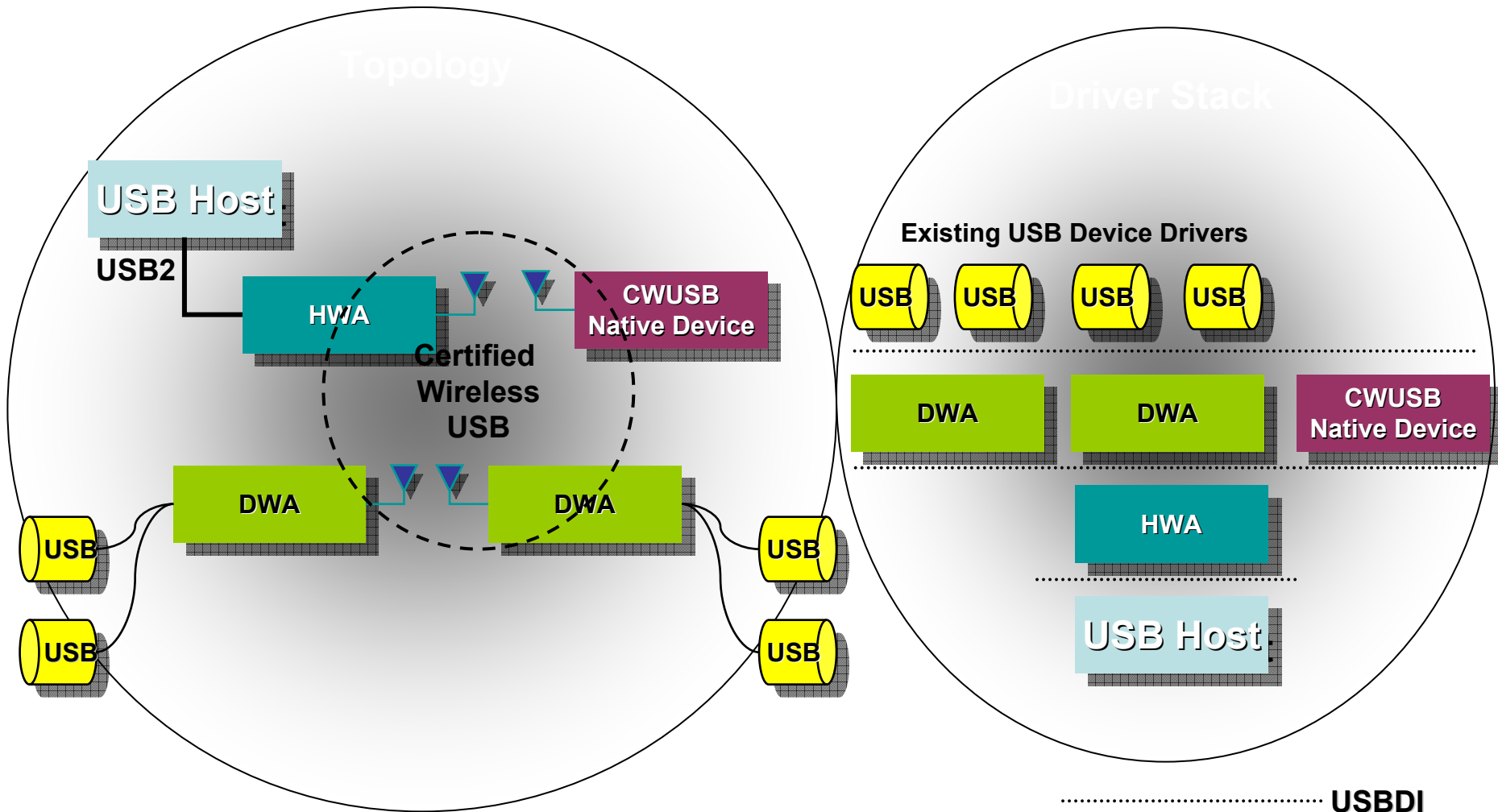

Data Transfer Overview: USB

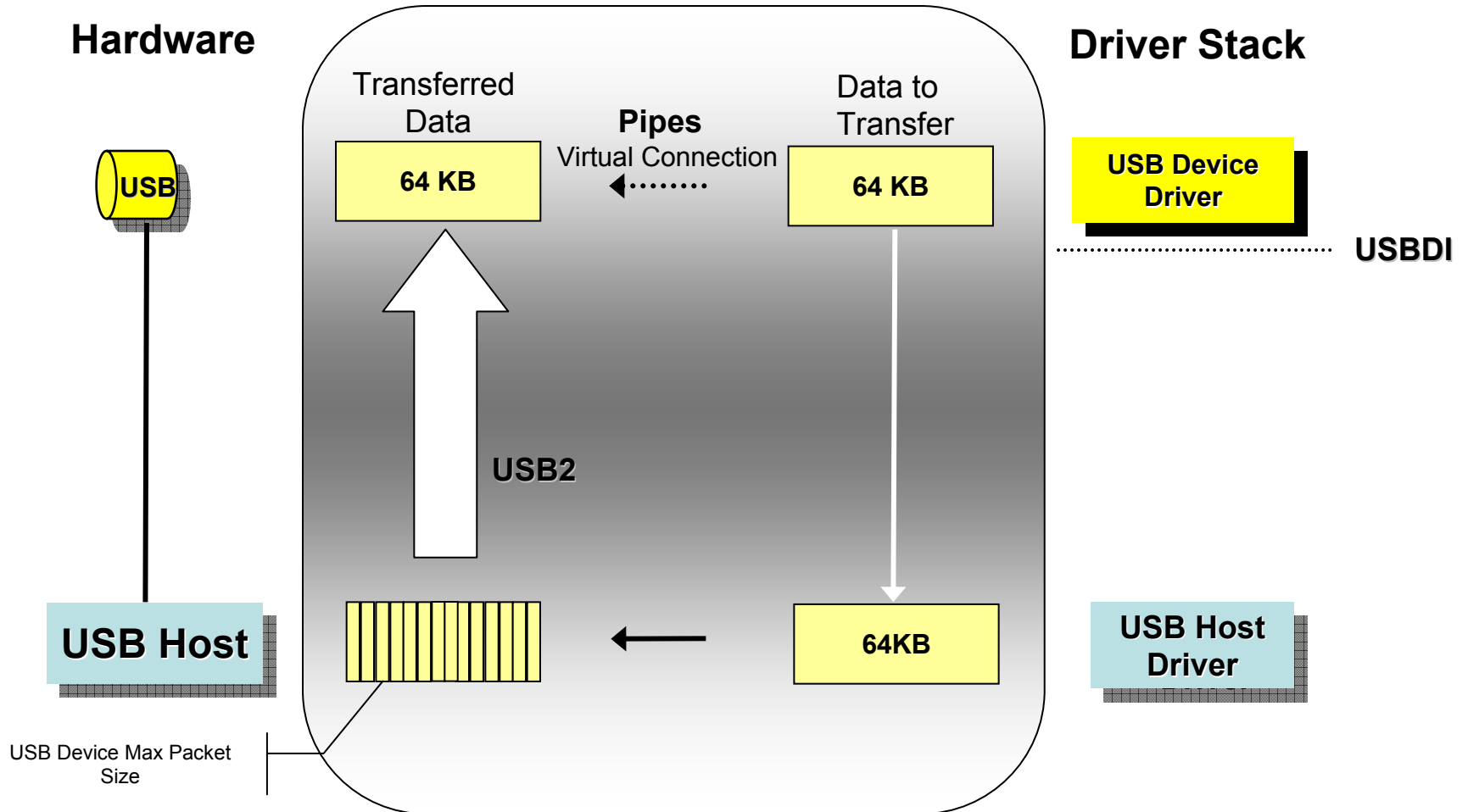
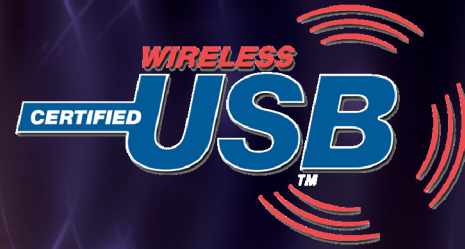

Data Transfer Overview: Certified Wireless USB

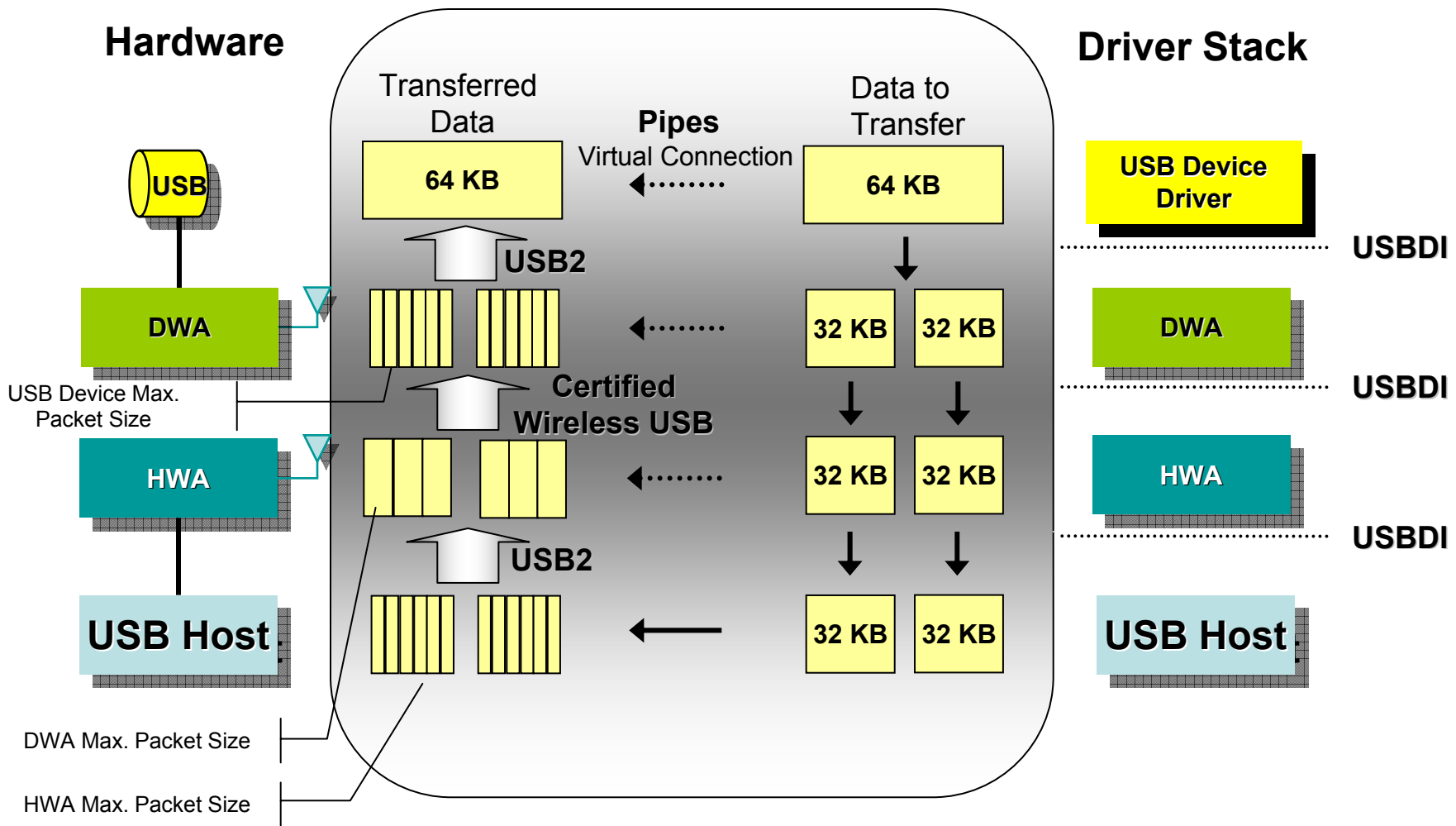

Agenda



- Overview
- Software-Hardware Overview
- **Data Delivery Mechanism: RPipe**
- Hardware Architecture
- Wire Adapter Device Class
- Software Architecture
- Summary

Basic Theory of Data Delivery

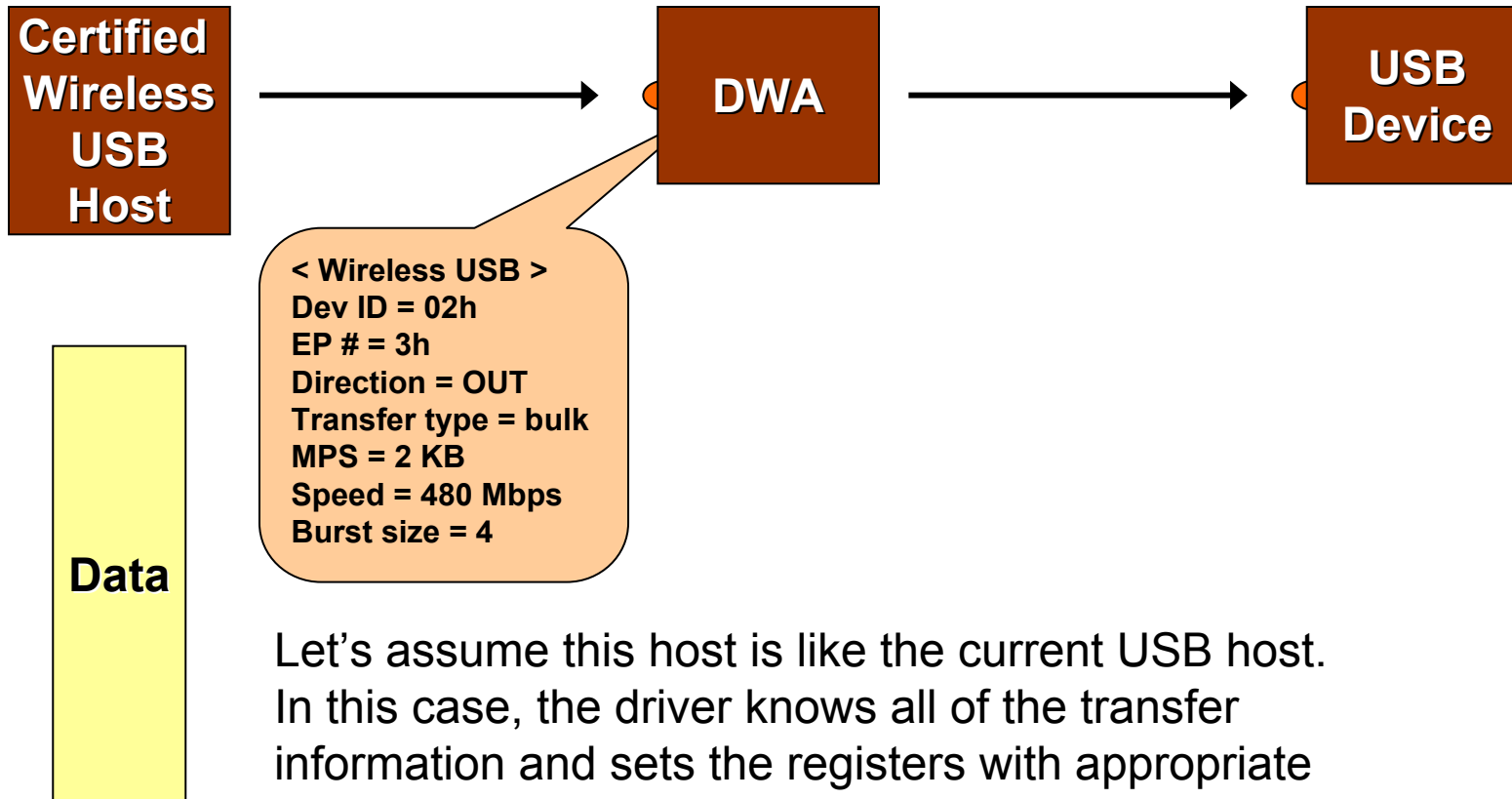

Let's assume this host is like the current USB host. In this case, the driver knows all of the transfer information and sets the registers with appropriate values to transfer the data to the DWA.

Basic Theory of Data Delivery

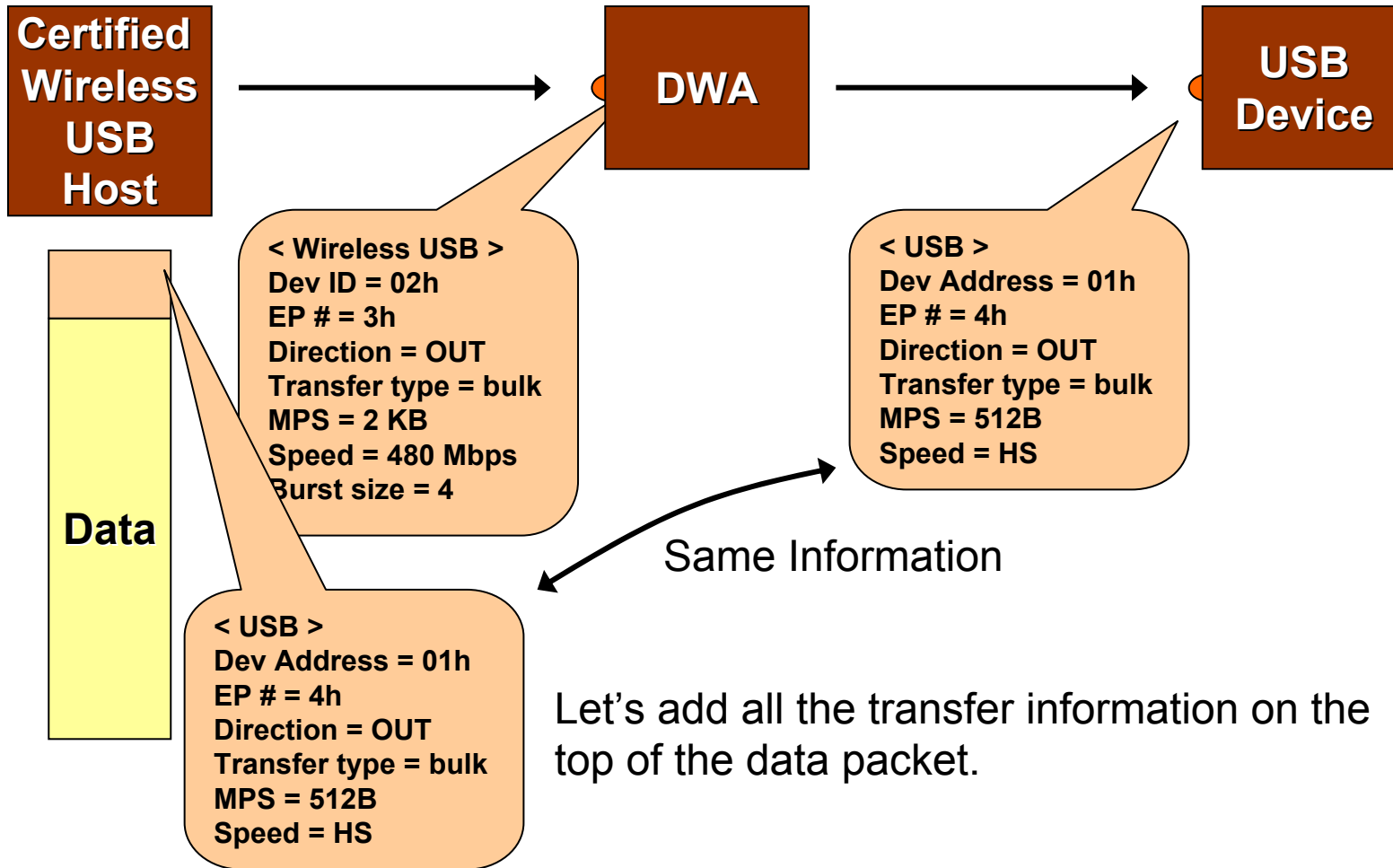

Basic Theory of Data Delivery

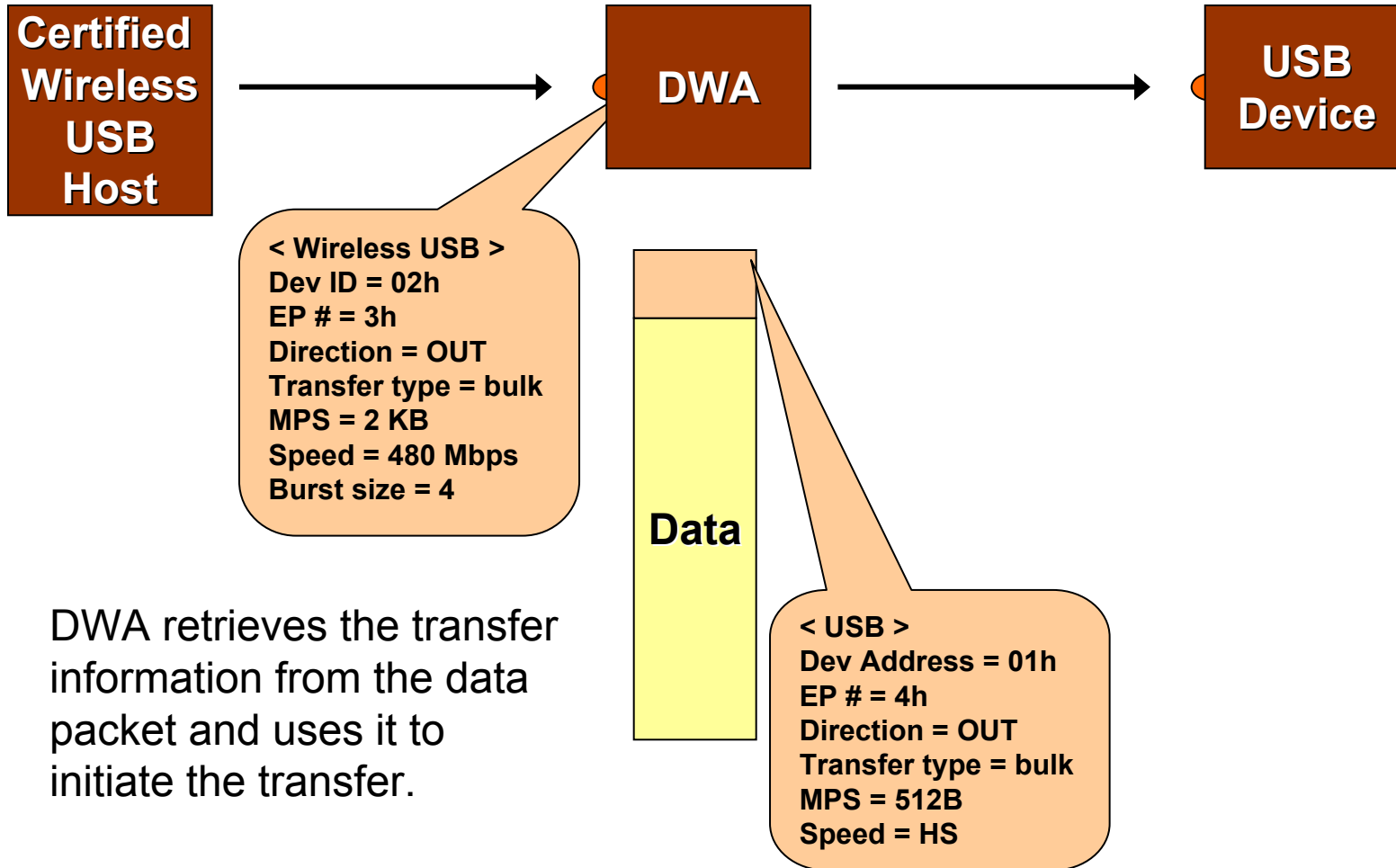

Basic Theory of Data Delivery

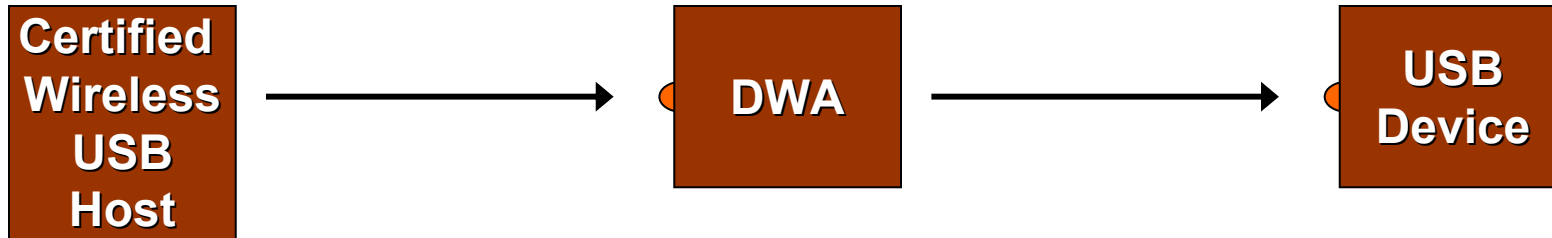

Delivered!

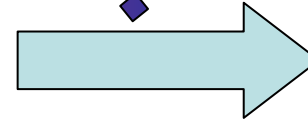

Local Database of Transfer Information

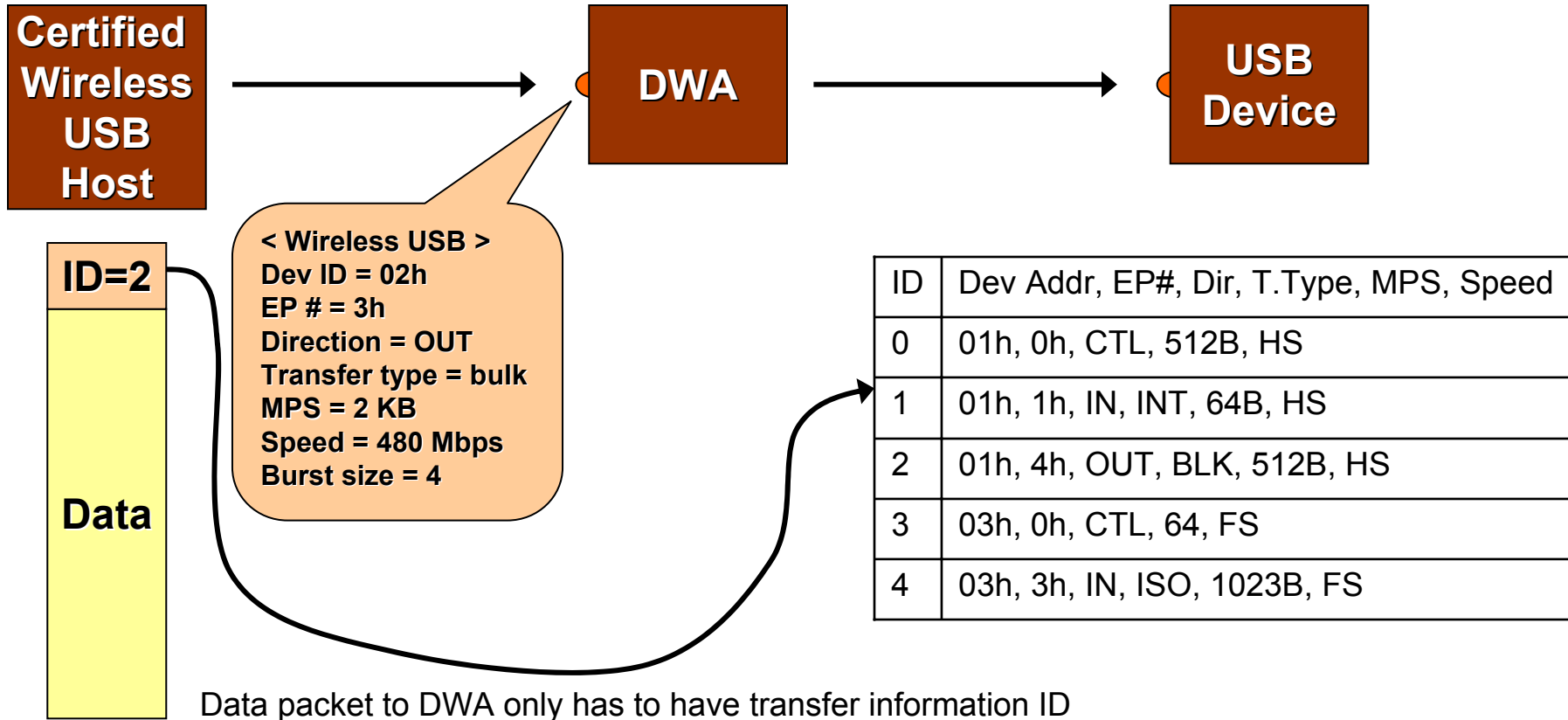

Local Database of Transfer Information

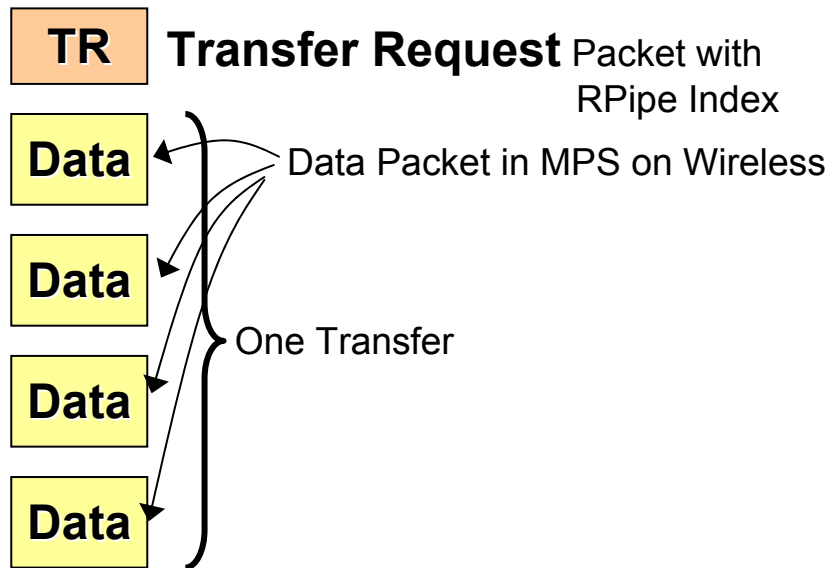
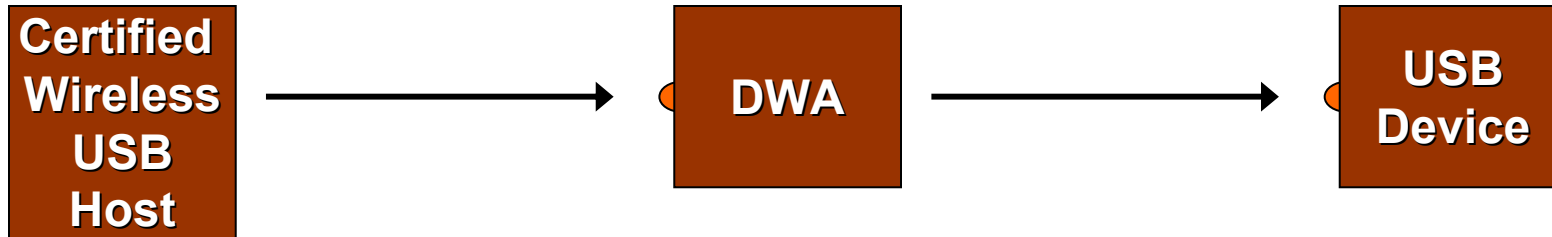

ID	Dev Addr, EP#, Dir, T.Type, MPS, Speed
0	01h, 0h, CTL, 512B, HS
1	01h, 1h, IN, INT, 64B, HS
2	01h, 4h, OUT, BLK, 512B, HS
3	03h, 0h, CTL, 64, FS
4	03h, 3h, IN, ISO, 1023B, FS

Each transfer information set is called
 “Remote Pipe”, or **“RPipe”**

Data Delivery Summary



TR
TR
Data

Host Wire Adapter and Device Wire Adapter

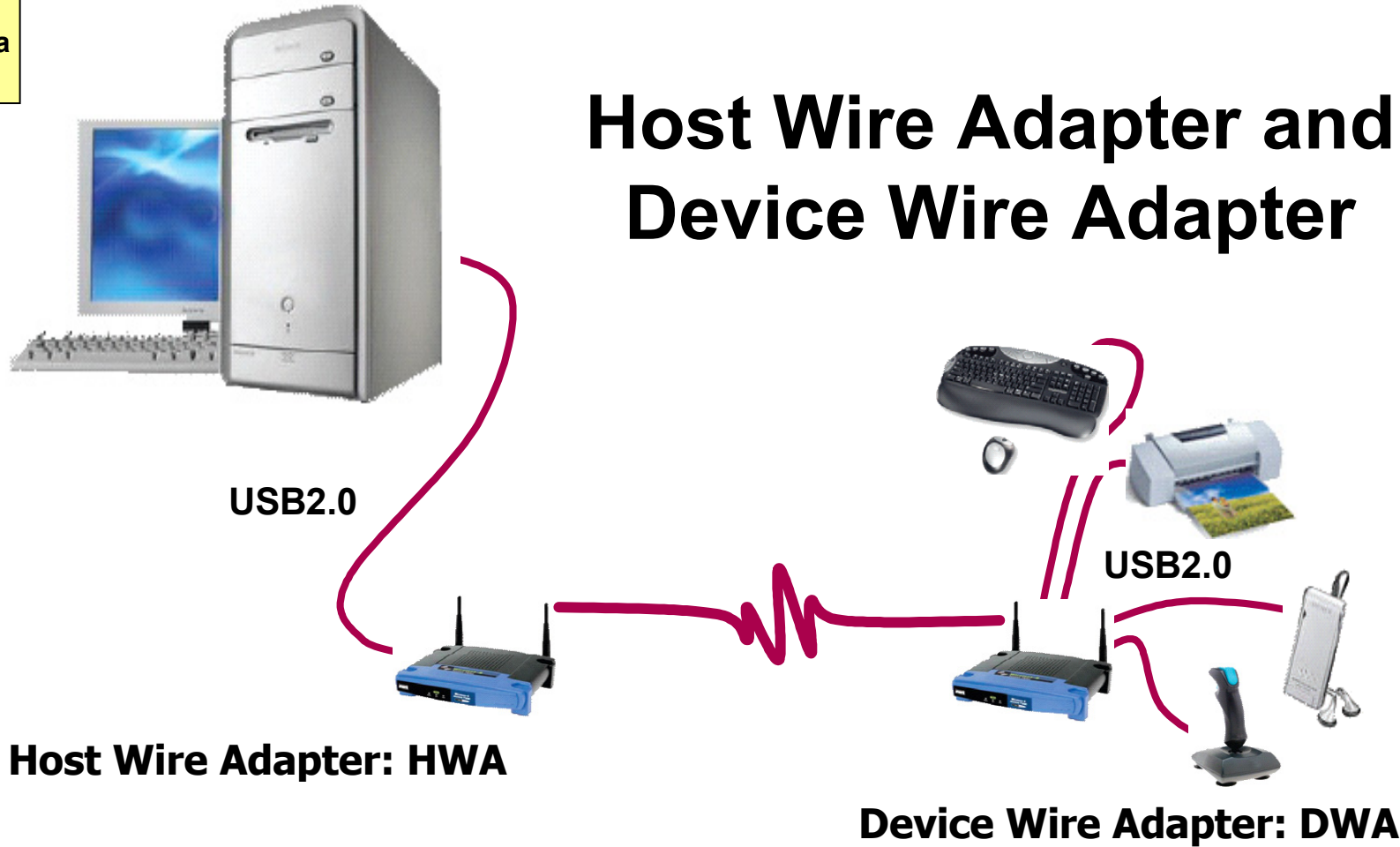

Data Delivery Summary

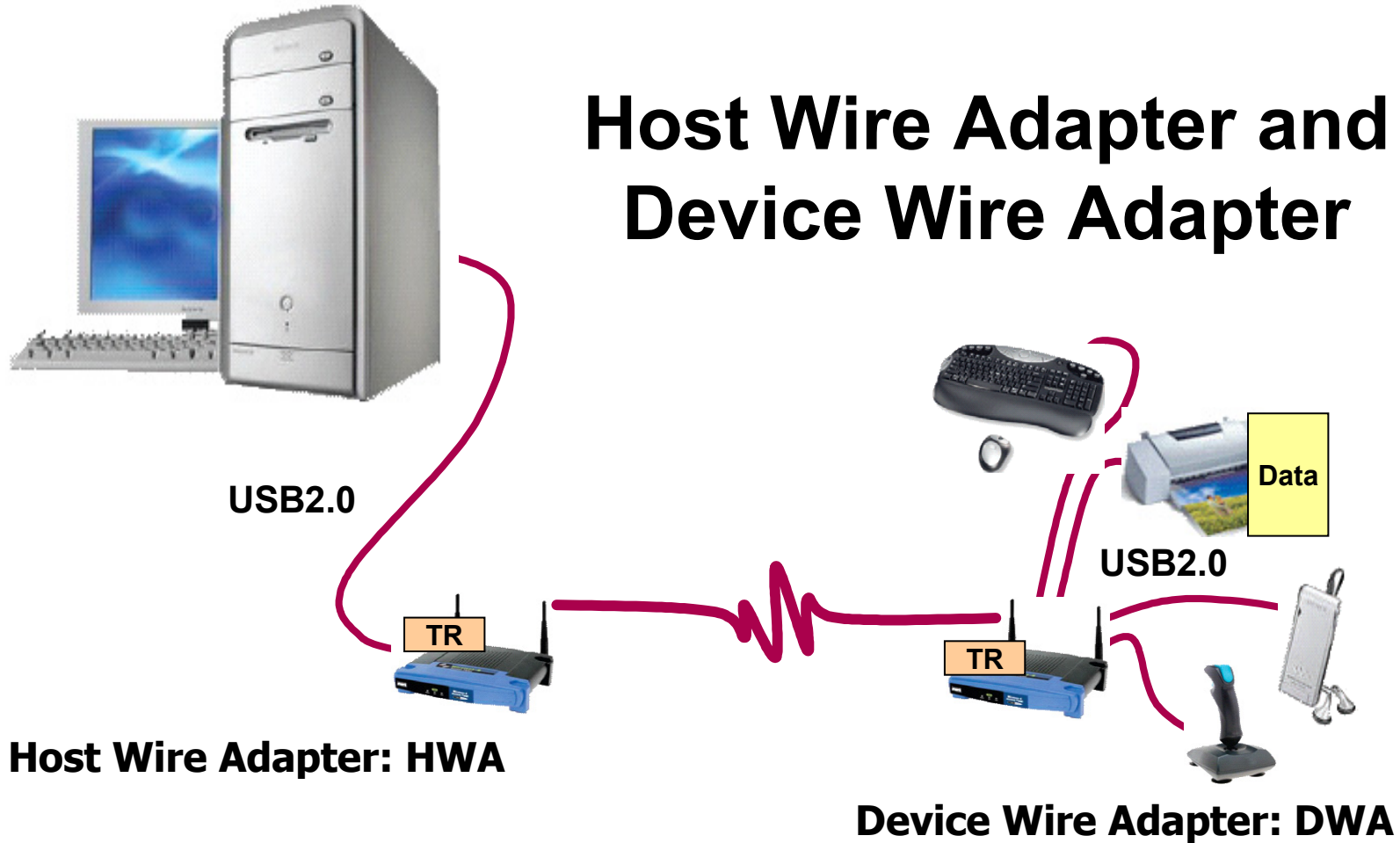

Data Delivery Detail: Bulk, Control

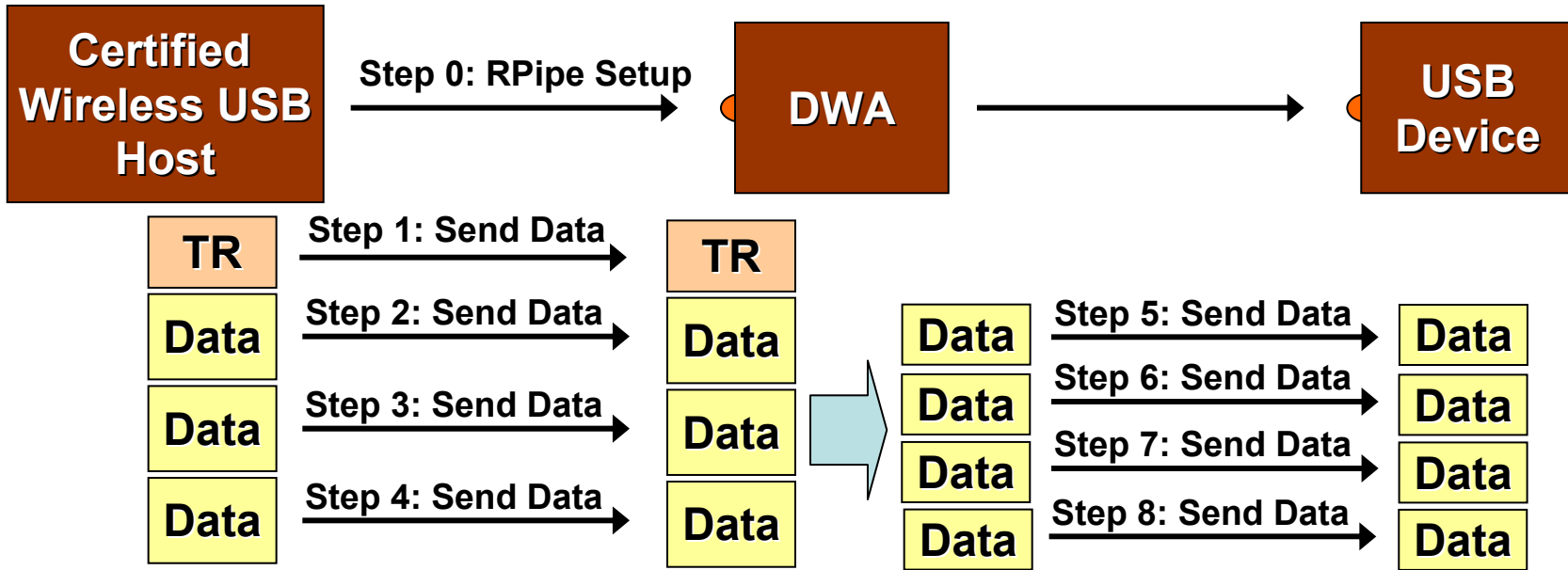

This Period varies

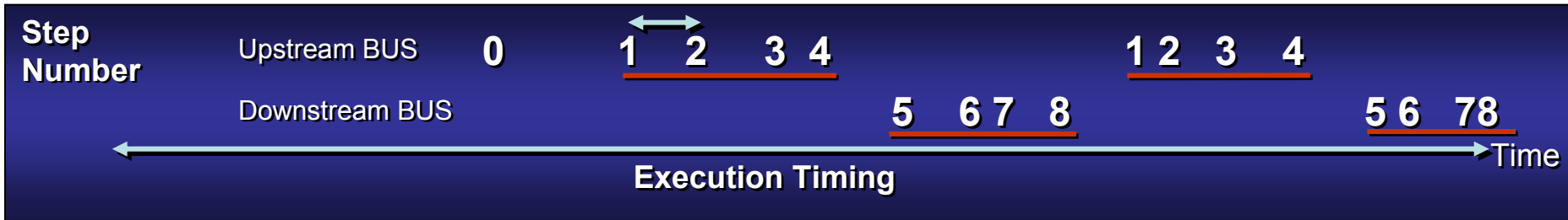

Data Delivery Detail: ISO

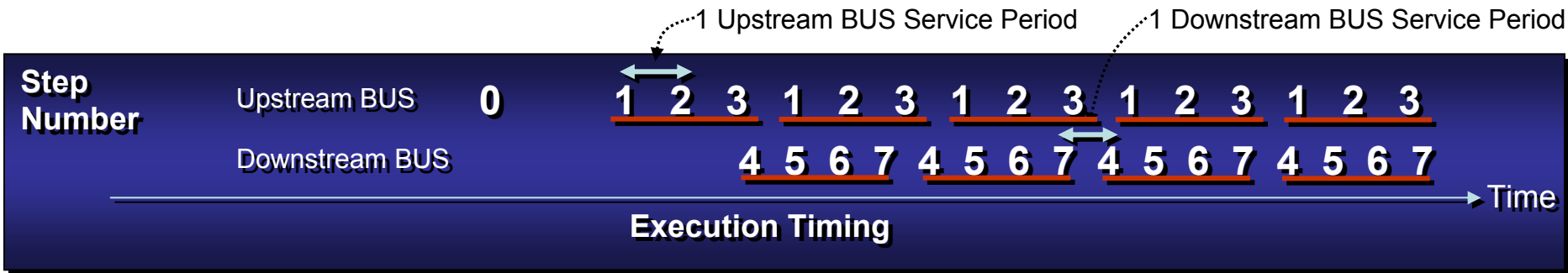
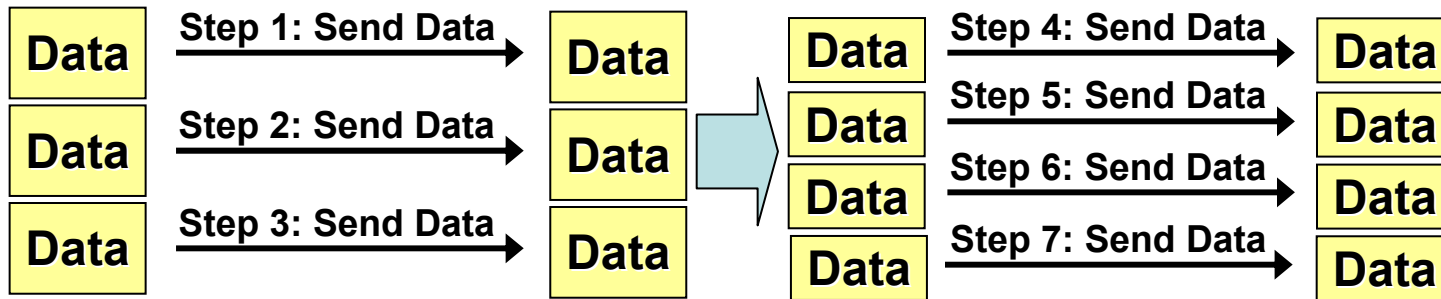
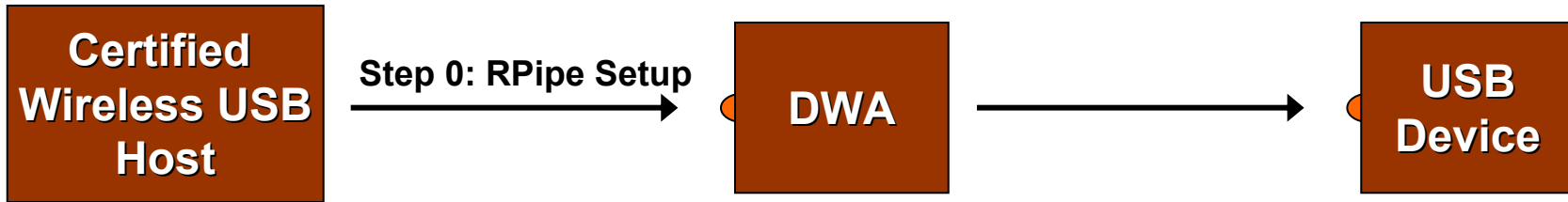



Agenda

- Overview
- Software-Hardware Overview
- Data Delivery Mechanism: RPipe
- **Hardware Architecture**
- Wire Adapter Device Class
- Software Architecture
- Summary

Hardware Architecture

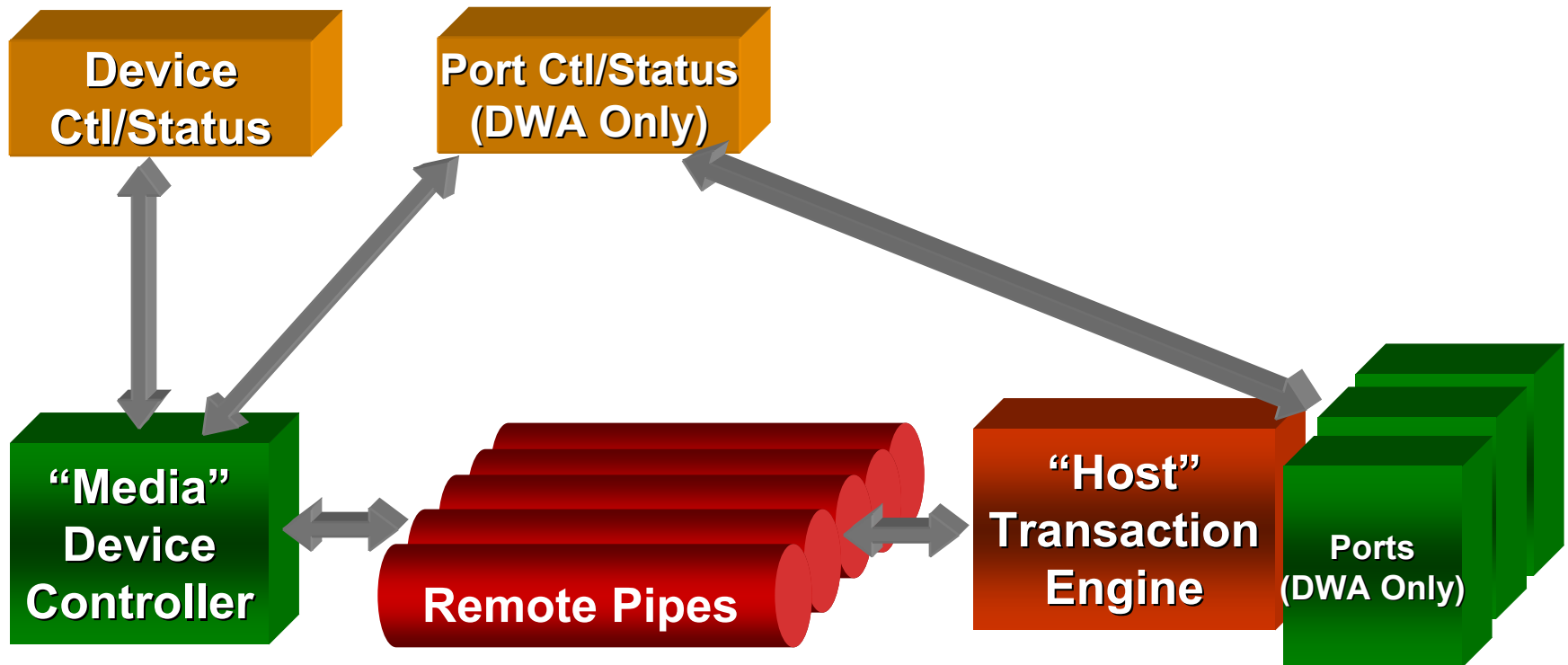
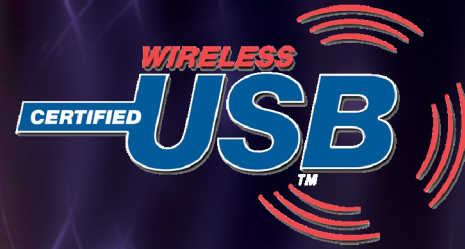

Media Device Controller



- Handles upstream communications with host
- Choice of upstream media type is dependent on the type of WA
 - HWA: USB 2.0 device controller
 - DWA: Certified Wireless USB device controller
- Processes wire adapter class-specific requests
- Handles USB / Certified Wireless USB standard requests
 - Usually implemented as endpoint controller

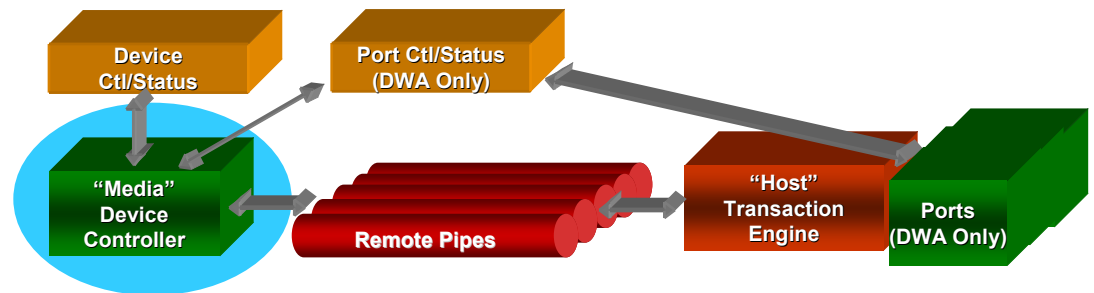

Device Control and Status



- Provides device control and status information
- Controlled using standard and class specific USB command
- Standard requests
 - Get device descriptor
 - Set address
- Class-specific requests
 - Get wire adapter status
 - Set/clear wire adapter feature

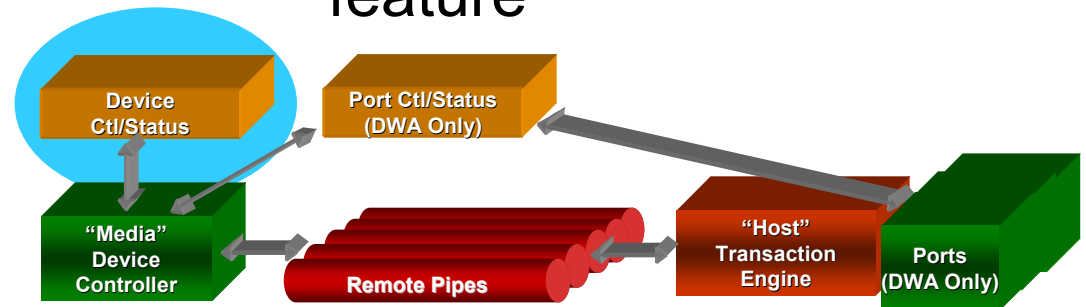

Port Control and Status



- Ports are only present on DWAs
- Similar to port control of wired USB 2.0 hub
- Controls the physical downstream ports on a device wire adapter
- Controlled using class specific CWUSB requests
 - Class-specific root Port requests
 - Reset
 - Enable/disable
 - Suspend/resume

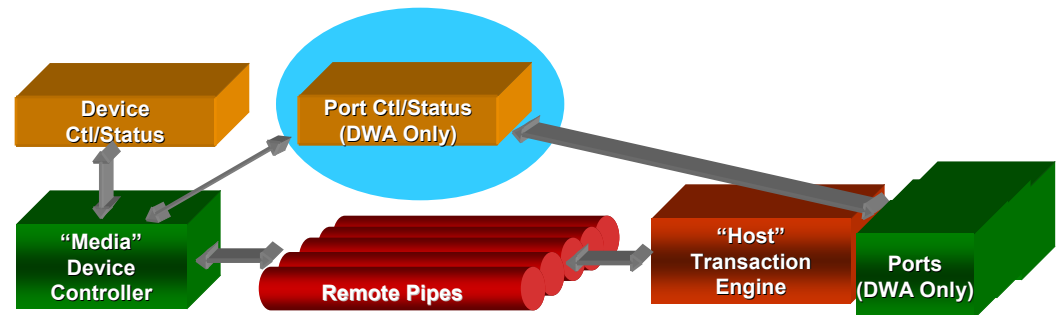

Remote Pipe



- RPipe attributes
 - Endpoint context
 - Amount of buffer /RPipe
 - Number of requests
 - Type of transfer
- Re-configuration of RPipe
 - Get RPipe and save
 - Set RPipe w/new
 - Restore w/set RPipe w/old descriptor accept transfer requests and data from host
- Min. 1, max. 3937
 - Recommended – 2× number of supported devices

• Functions

- Convert transfer requests to individual transactions
- Pass transactions to host transaction engine
- Return transfer status and data to host
 - OUT: transfer result
 - IN: transfer result + data received from device

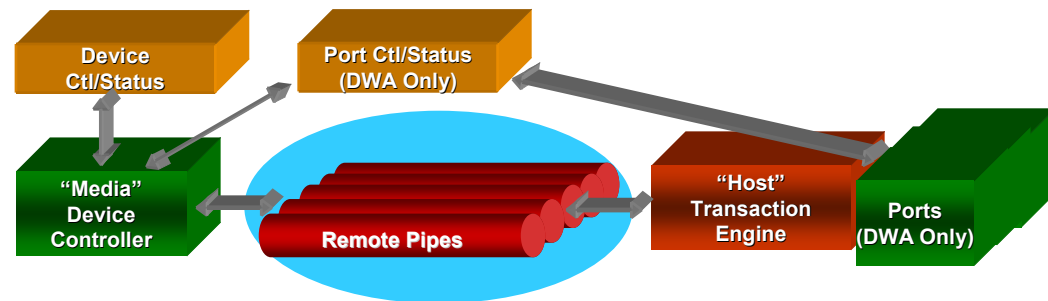

Host Transaction Engine



- RPipes provide the work to be done
 - Data and control information
- Transaction control
 - SOF and token generation (DWA)
 - MMC and W_x CTA generation (HWA)
- Prioritize RPipe by transfer types
 - Priority service to periodic RPipes
 - Isochronous, interrupt
 - Round-robin service to asynchronous RPipes
 - Bulk, control

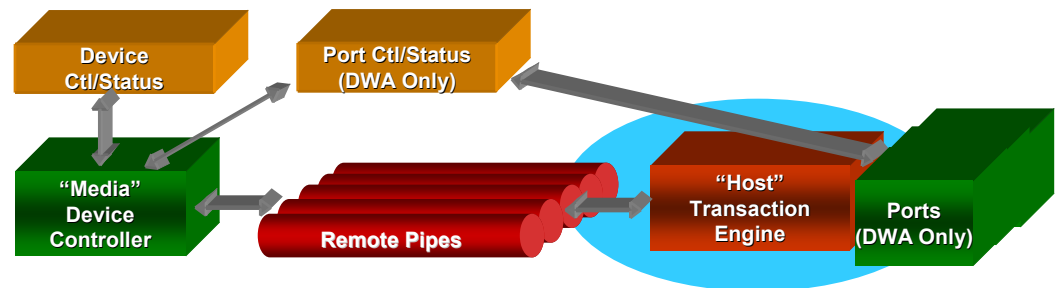

Synchronization Timing

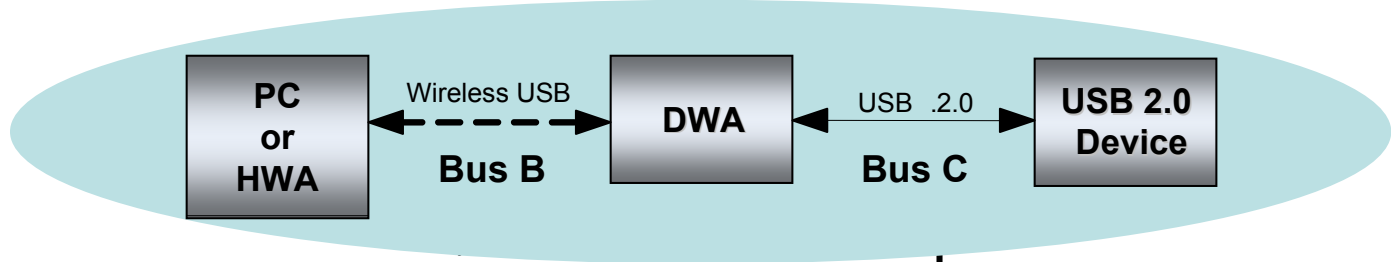

Bus Timings

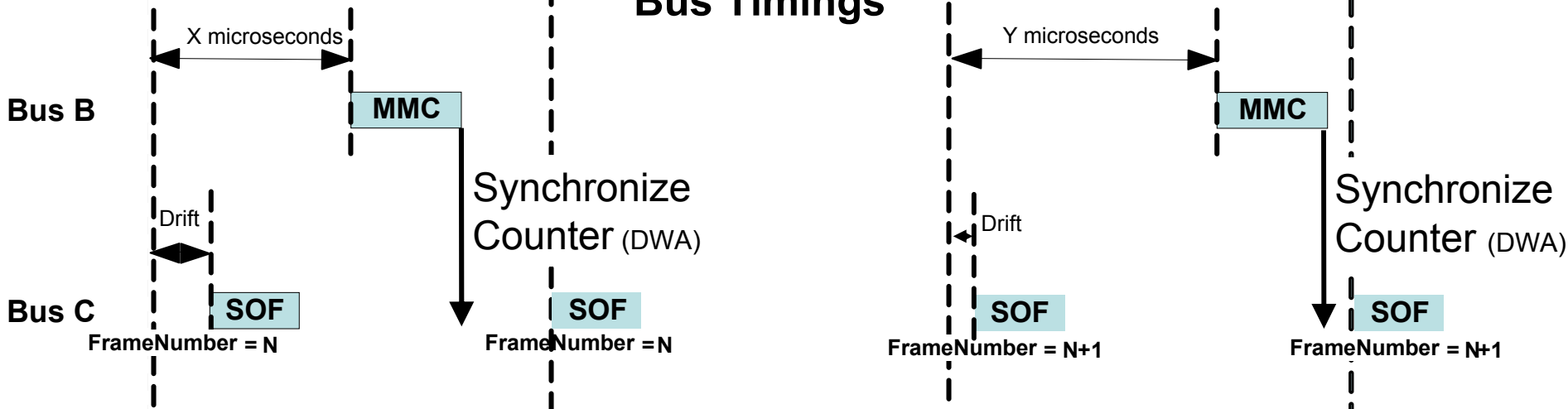

All clocks under an HWA are synchronized

- Device wire adapters
- Certified Wireless USB devices

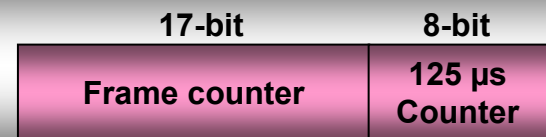

Architecture Summary



- Wire adapters expose a USB interface
 - Host wire adapter is a USB 2.0 device
 - Device wire adapter is a Certified Wireless USB device
- Scalability
 - No data rate relationships between layers
 - Specification allows vendors to develop both complex wire adapters as well as simple dedicated wire adapters
 - Cost sensitivity
- Managed within the USB device framework
- Buffer oriented data delivery model
- DWAs synchronize their downstream USB clock to the upstream Certified Wireless USB clock

Agenda



- Overview
- Software-Hardware Overview
- Data Delivery Mechanism: RPipe
- Hardware Architecture
- **Wire Adapter Device Class**
- Software Architecture
- Summary

Wire Adapter Device Class

- The class definition describes the USB interface to a WA
 - Descriptors (standard and class-specific)
- Describes wire adapter data delivery model
- Applies to both host and device wire adapters

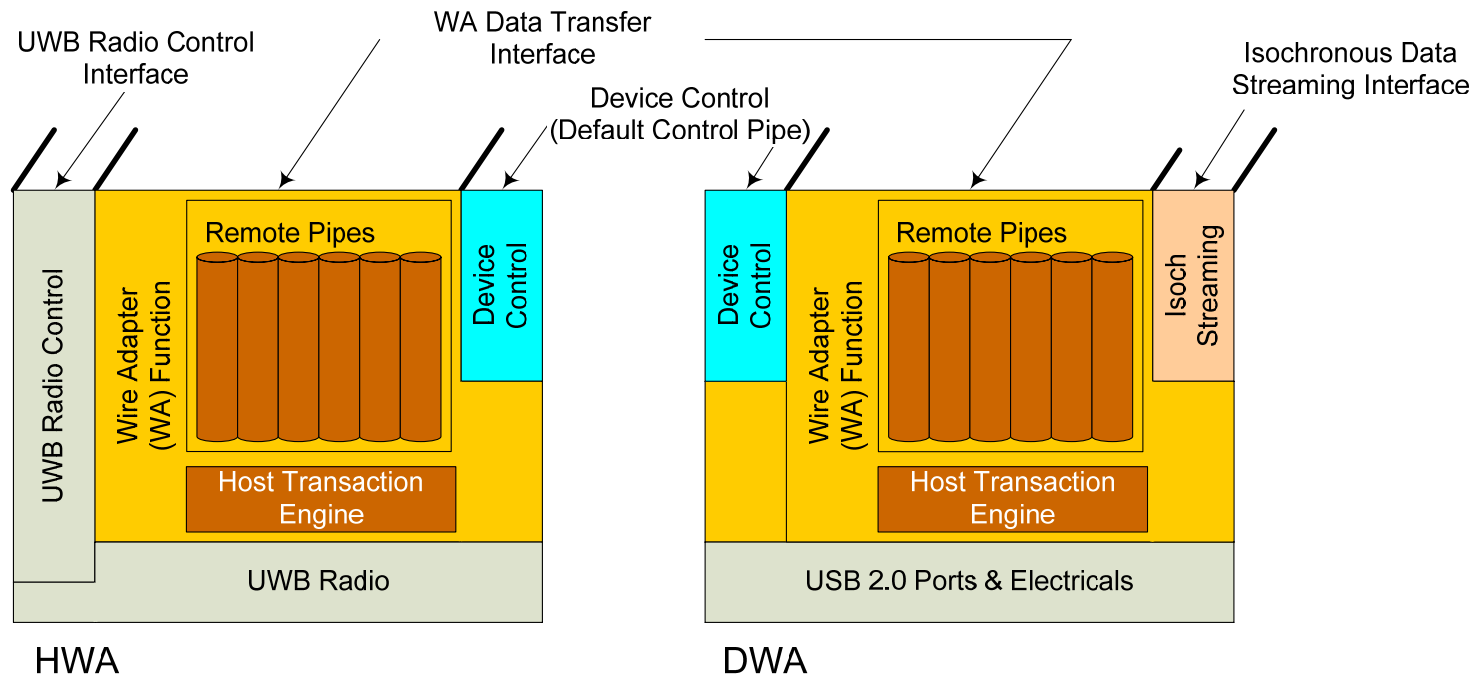

Wire Adapter Device Control



- The default endpoint is used to manage the WA device
- Categories of requests:
 - Wire adapter control
 - Remote pipe control and status
 - Port control and status (DWA only)
 - Association and security (HWA only)

Wire Adapter Control

- Ability to reset, enable/disable the wire adapter
 - Set/clear wire adapter feature
- Get the current status of the wire adapter
 - Get wire adapter status

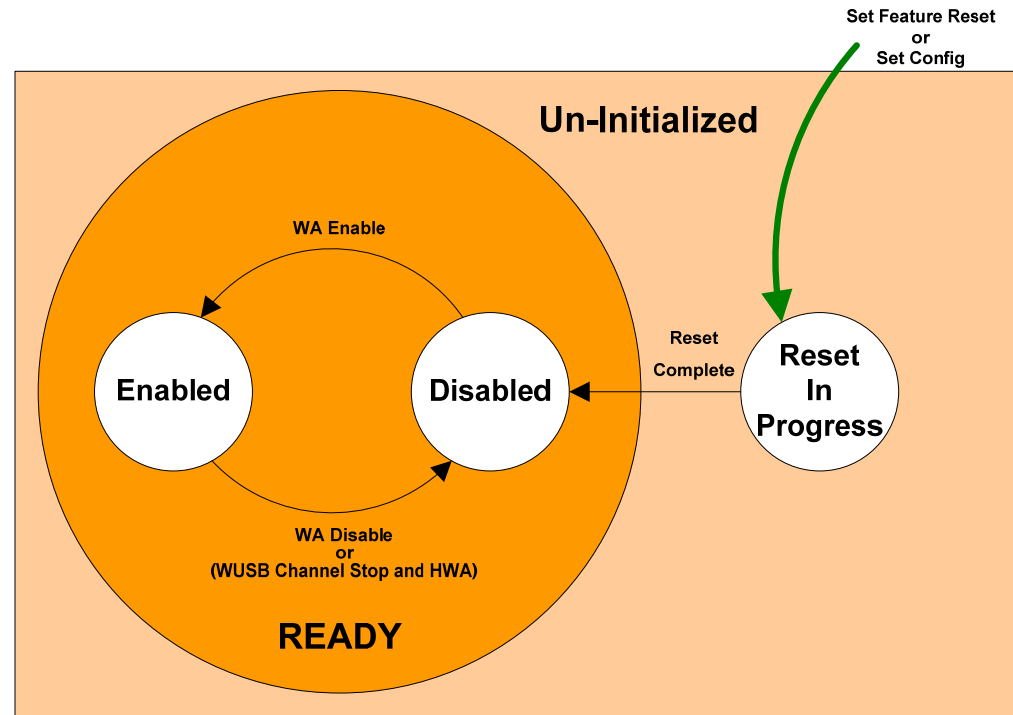

Host Wire Adapter Control



- Add/remove information elements from an MMC
 - Add/remove MMC IE
- Set the interval and number of DNTS slots
 - Set Num DNTS Slots
- Set the device availability info
 - Set device info
- Time-related information
 - Get BPST time
 - Get WUSB time

Remote Pipe Control and Status



- This is the heart of the wire adapter
- The number of RPipes is returned in the WA class-specific WA descriptor
- Each RPipe is described by an RPipe descriptor
 - Get RPipe descriptor
- Set RPipe descriptor is used to change the buffer size, transfer type, number of retries, endpoint context on an RPipe

Remote Pipe Control and Status – 2



- Transfers on an RPipe may be aborted
 - Abort RPipe
- An RPipe can be temporarily paused
 - Pause RPipe
- Host software can get the current state of the RPipe
 - Get RPipe Status

HWA Association and Security



- A host wire adapter provides support to connect a device with a Certified Wireless USB host
 - DN Received notification sent to the host when a DN_Connect is received
 - Hosts add a WCONNECTACK_IE in response using the Add MMC IE request
- Uses a security descriptor to identify the encryption types supported
- Supports using individual encryption types for each downstream device
 - Set device encryption
 - Set device key
- Provides a mechanism to set the key used to communicate with the Certified Wireless USB cluster
 - Set Group Key

Wire Adapter Data Transfer Interface



- A wire adapter exposes an interface with 3 endpoints
- Notification endpoint
 - Interrupt IN endpoint that provides notifications to the host, including asynchronous wire adapter status changes and transfer status, port status changes (DWA Only), WUSB device notifications (HWA Only)
- Data transfer endpoint pair
 - Bulk OUT endpoint used to send transfer requests and transfer data to the wire adapter
 - Bulk IN endpoint used to return transfer result and data from the wire adapter

Wire Adapter Data Transfer



- Transfer requests and transfer data to a downstream device are sent on the data transfer OUT endpoint
- All transfer requests contain an RPipe index
- The transfer request is sent as separate packet, followed by 'n' transfer data packets
 - Packetization information for an isochronous transfer request is sent immediately before the transfer data on an HWA
 - Packetization information is included in the Wireless USB header of the data packet for a DWA
- Transfer completion notification is returned on the notification endpoint
- Transfer result and data from a device is returned on the data transfer IN endpoint

Certified Wireless USB Device Enumeration

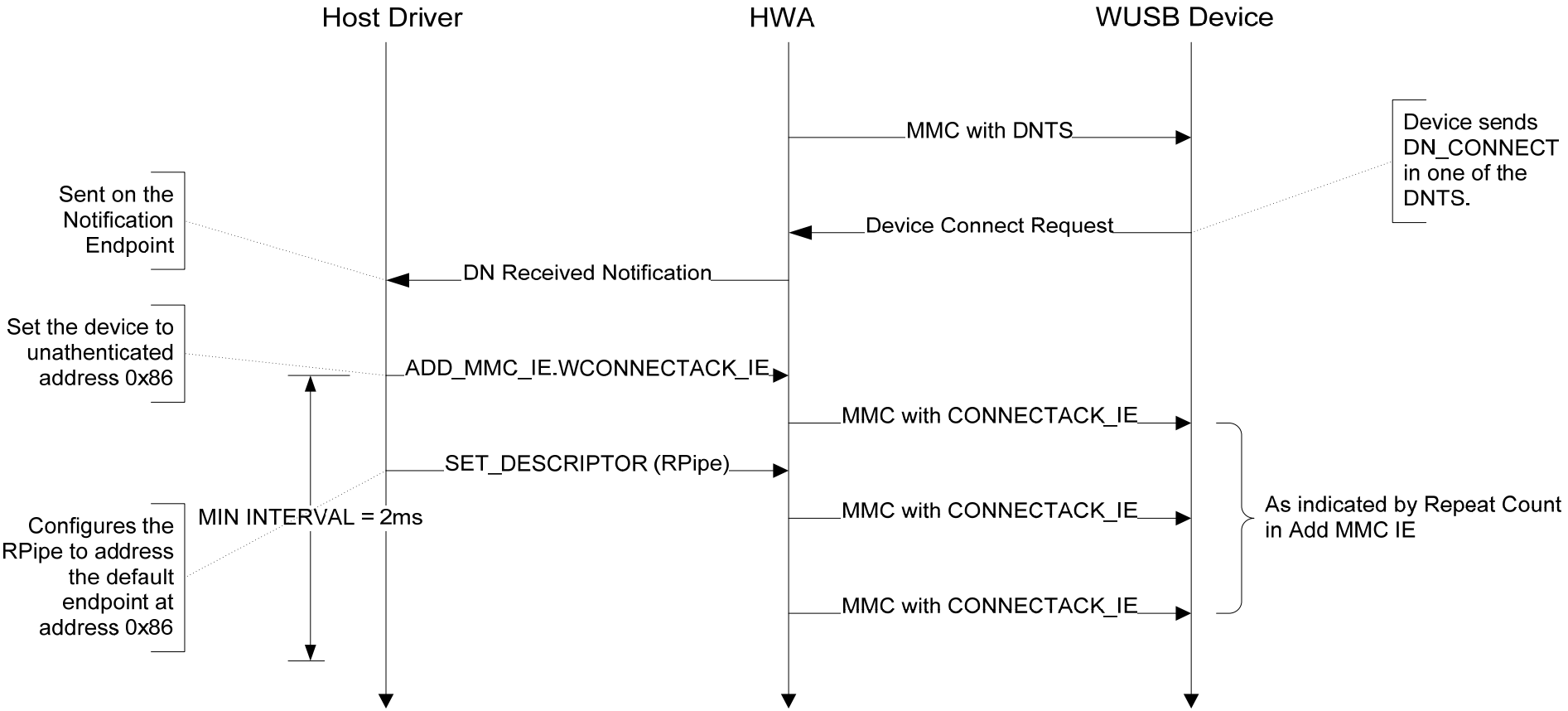

Continued...

Certified Wireless USB Device Enumeration

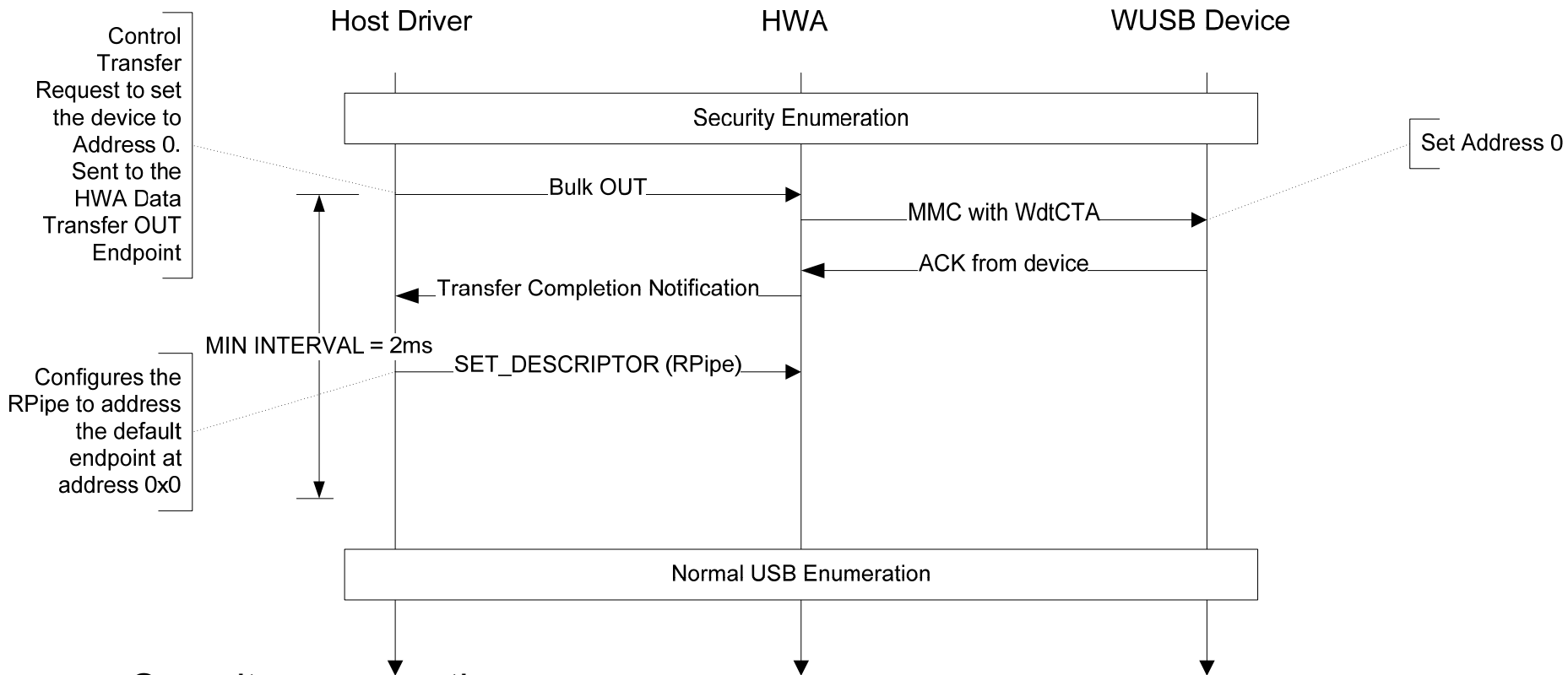
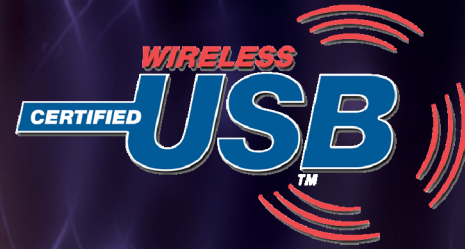

- Security enumeration
 - Get Security Descriptor, Set Encryption, 4-Way-Handshake
- Normal enumeration
 - Get Device Descriptor, Set Address, Get Configuration etc.

DWA Isochronous Streaming Interface



- Optional interface required to support Isochronous traffic
- Consists of 1 to 27 WUSB isochronous endpoints
- All endpoints support continuously scalable dynamic switching
 - Max. packet size and stream delay for a stream set using Set Isochronous Endpoint Attributes request
- Mapping from the upstream endpoint to the downstream endpoint is stored in an RPipe descriptor

DWA Isochronous Data Transfer



- A downstream USB isochronous endpoint has a matching upstream CWUSB isochronous endpoint
- Data to a downstream endpoint is sent to the corresponding upstream CWUSB endpoint
 - The DWA recovers packetization information and presentation time from the WUSB isochronous packets
- Data from a device is returned to the host on the corresponding DWA CWUSB isochronous IN endpoint
 - The DWA adds the packetization information and presentation time to the WUSB isochronous packets
 - The DWA drops data if the buffer overflows for that particular endpoint
- No Transfer Completion notification is returned



Agenda

- Overview
- Software-Hardware Overview
- Data Delivery Mechanism: RPipe
- Hardware Architecture
- Wire Adapter Device Class
- **Software Architecture**
- Summary

Software Architecture

HWA

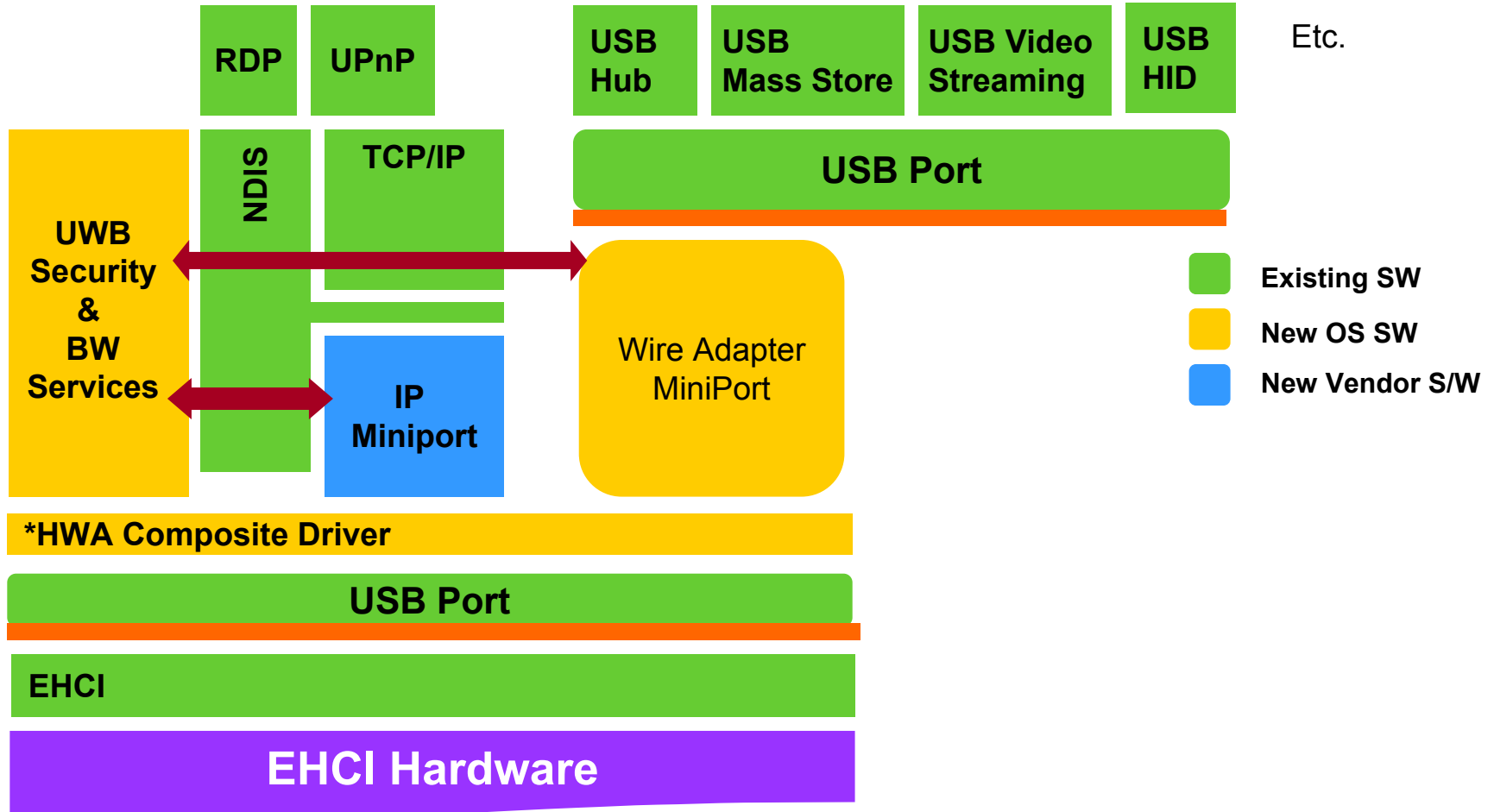
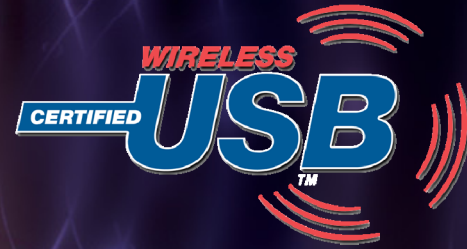

Summary



- Enabler of Certified Wireless USB technology
- Two types of wire adapters
 - HWA and DWA
- Defined as USB and Certified Wireless USB device
 - USB device framework
- Utilize current USB infrastructure
- New concept: remote pipe
- Proved concept
 - Prototypes from multiple companies



Back-up Slides

Read Request Sequence

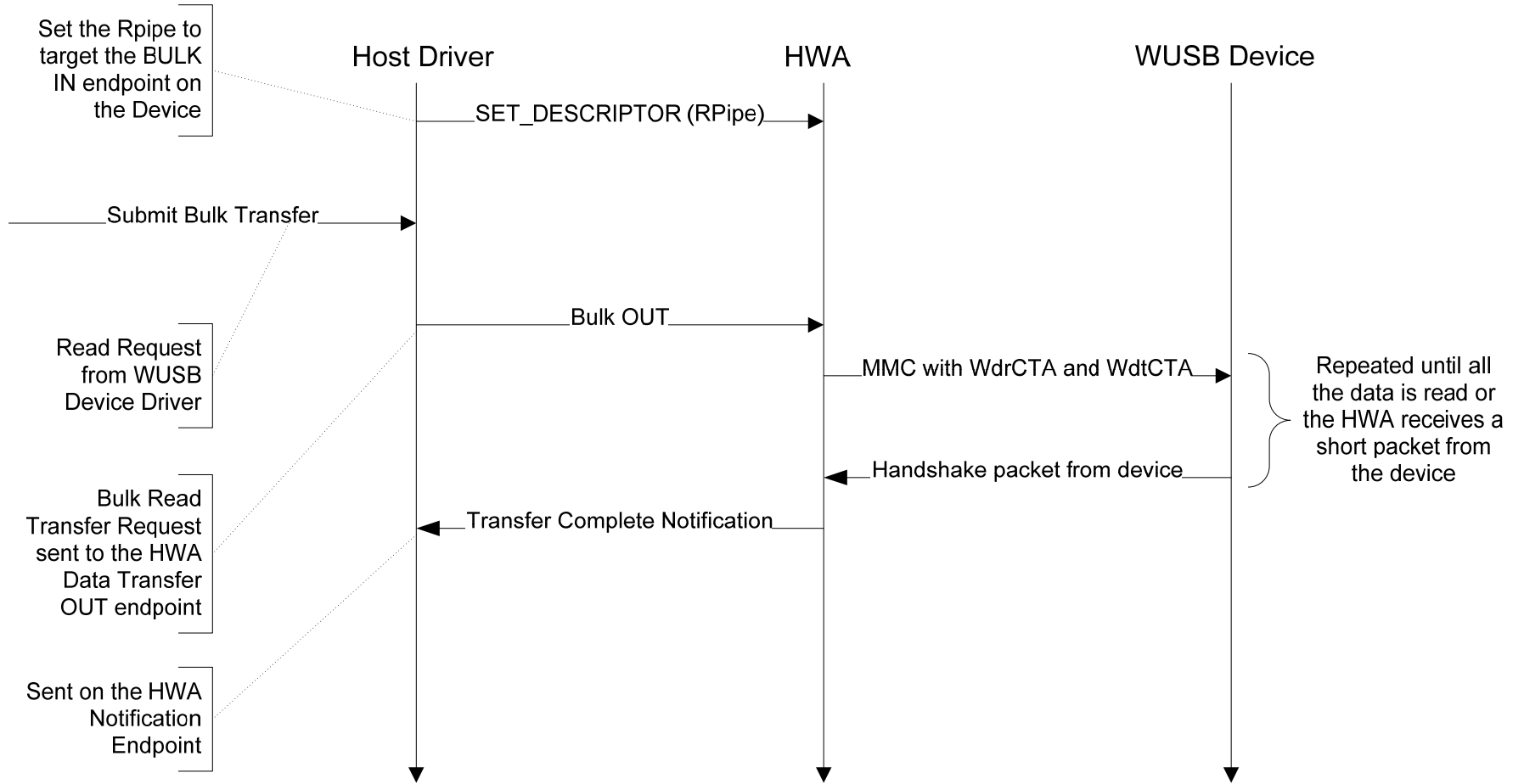

Continued...

Read Request Sequence

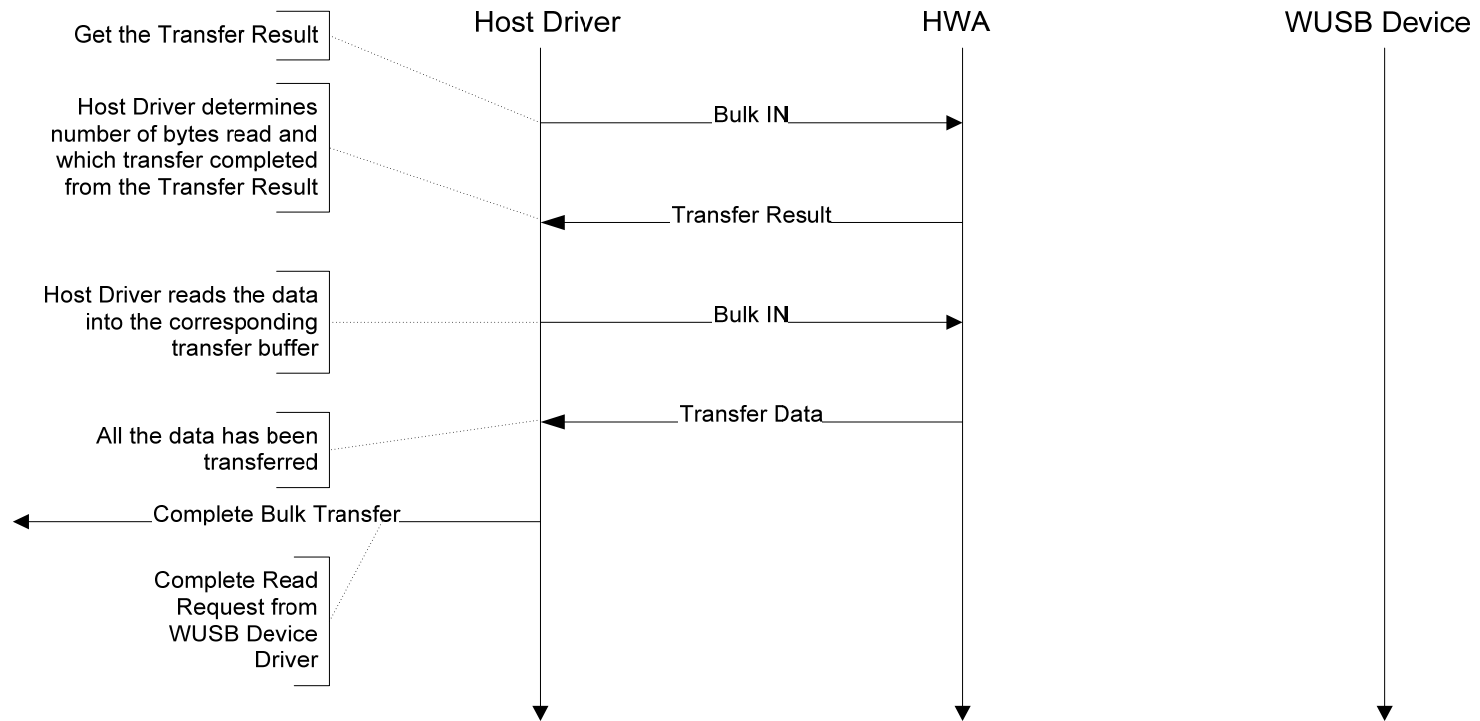

Data Flow - Request Sequence

Open Pipe Request

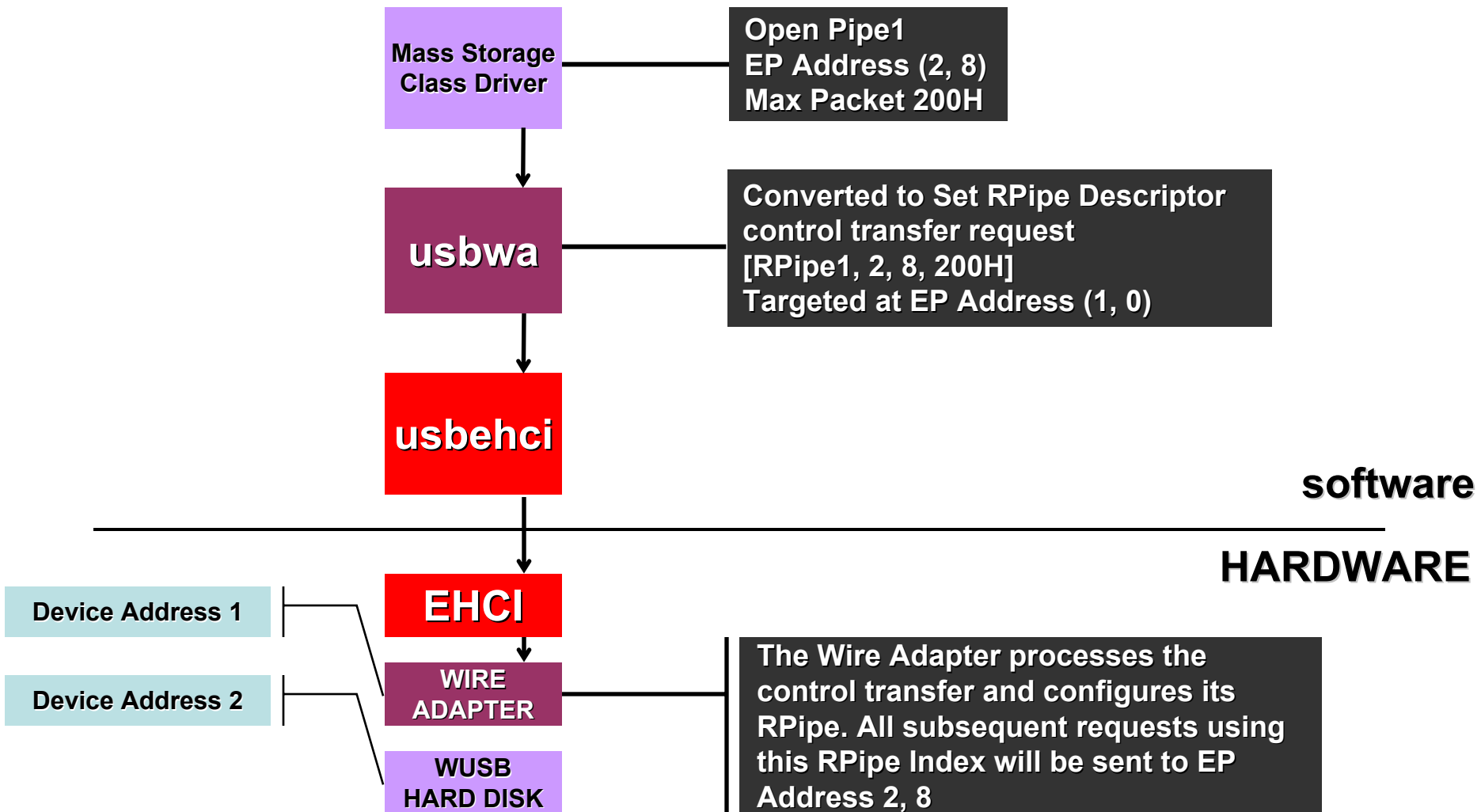

Data Flow – Request Sequence

Read Request – Bulk Transfer Request

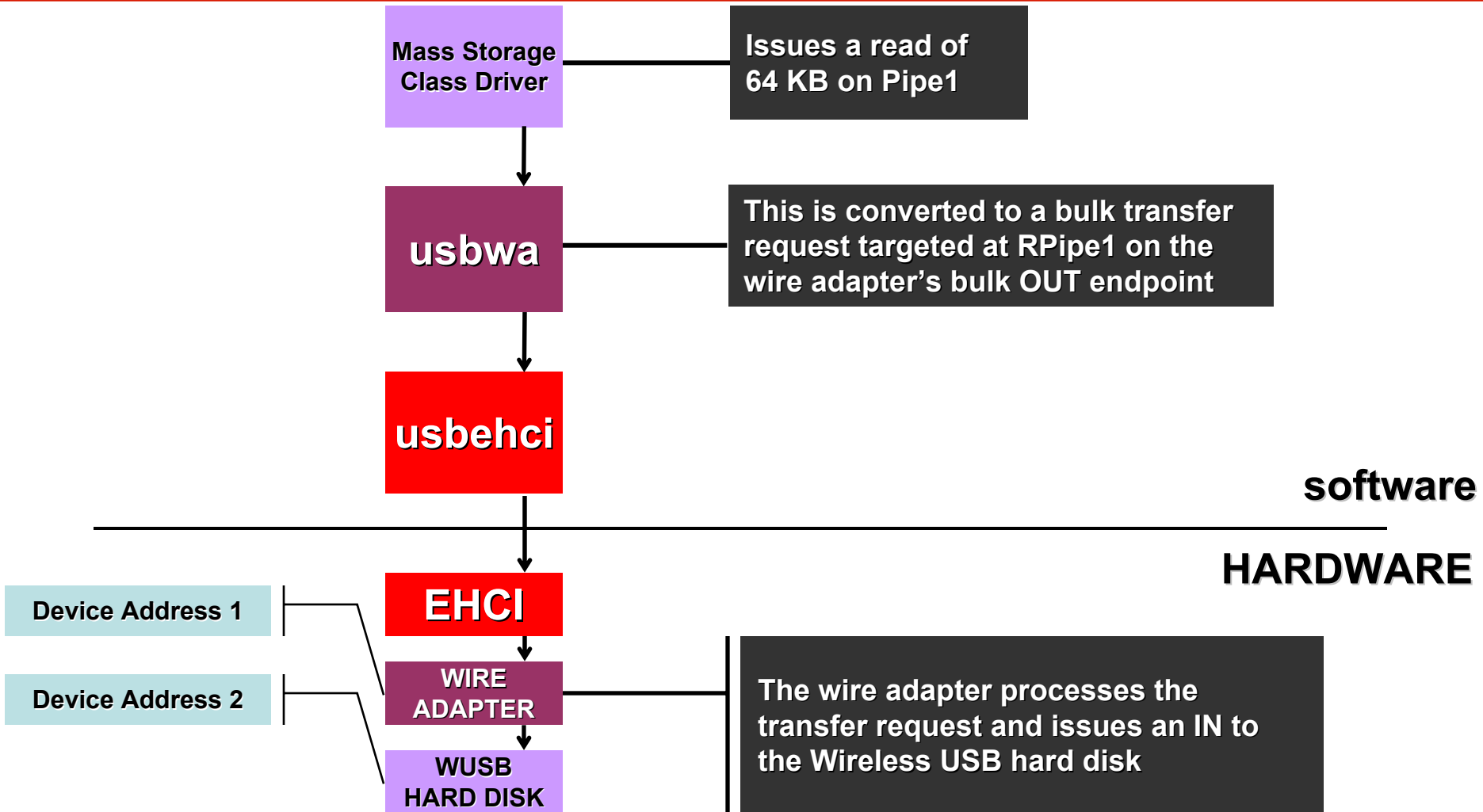

Data Flow – Request Sequence

Read Request – Transfer Completion Notification

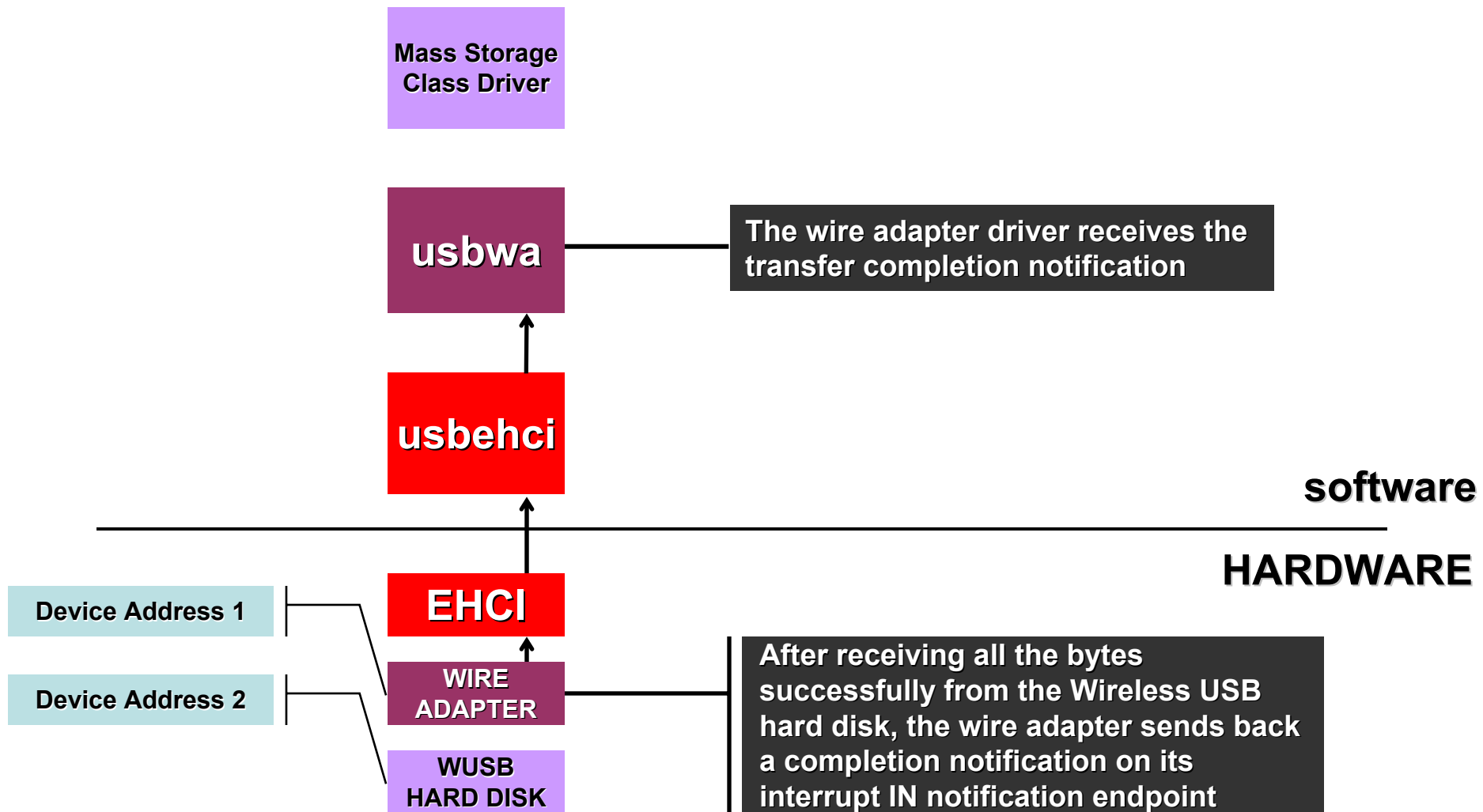

Data Flow – Request Sequence

Read Request – Transfer Result

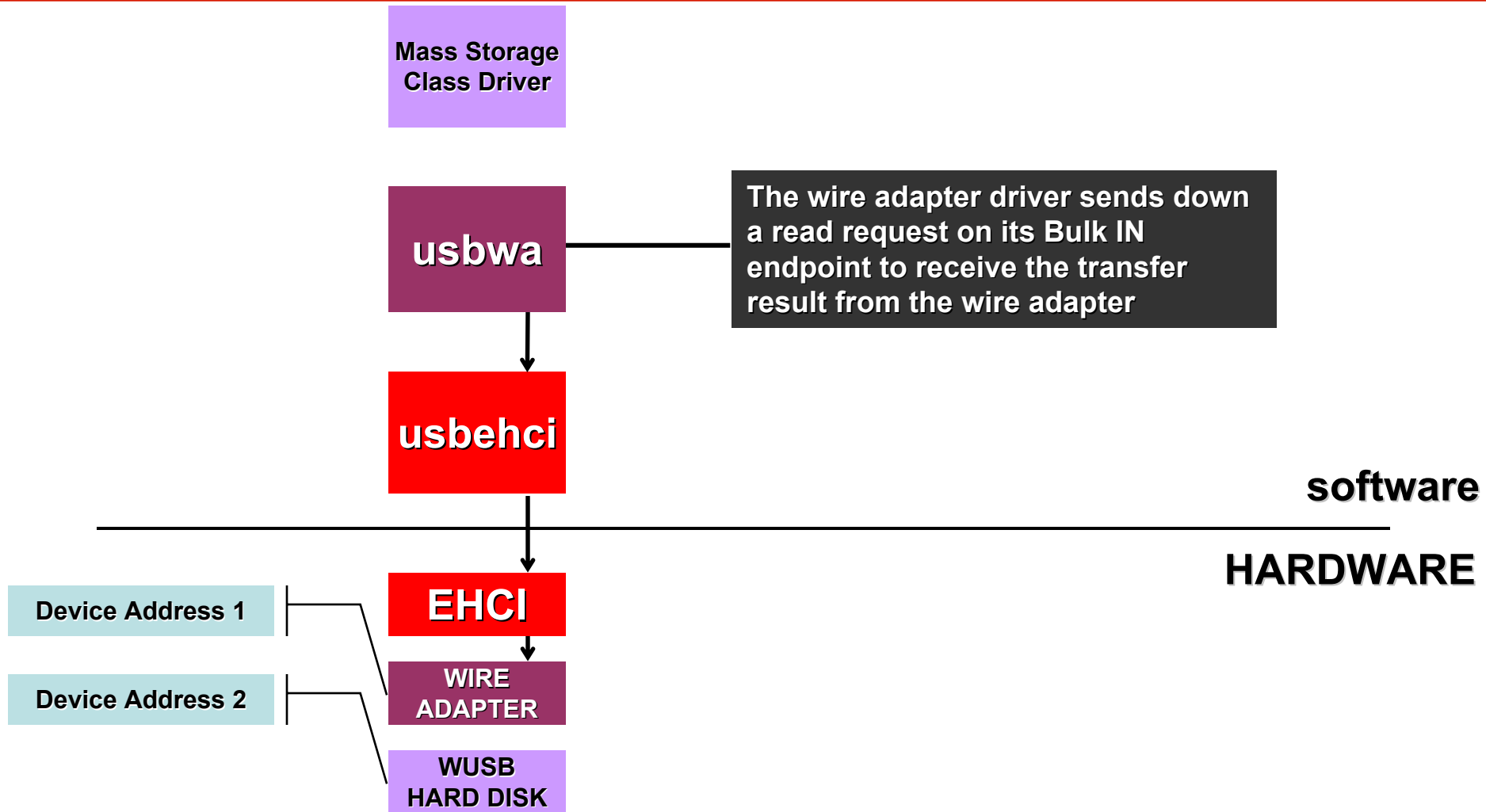

Data Flow – Request Sequence

Read Request – Transfer Result

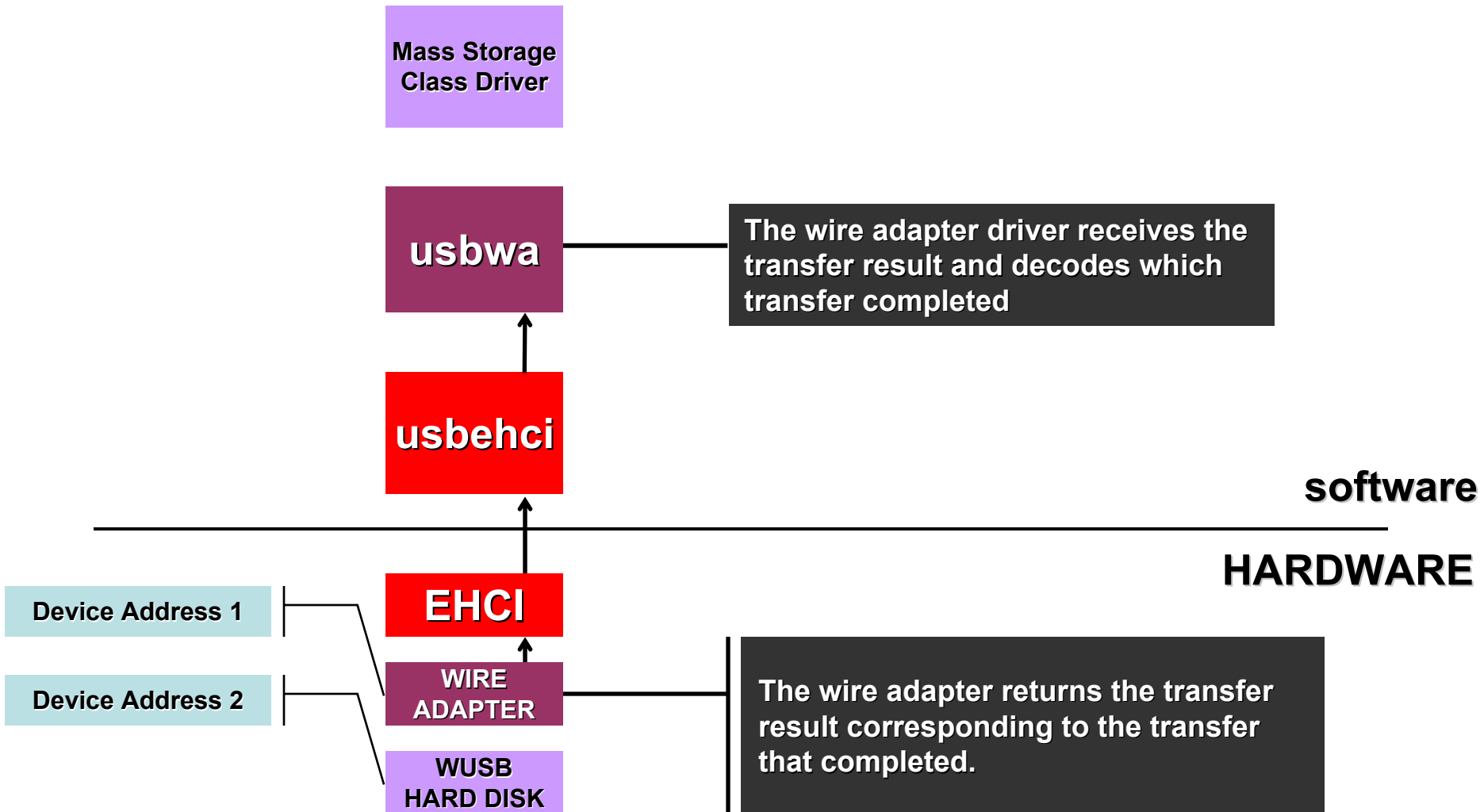

Data Flow – Request Sequence

Read Request – Transfer Data

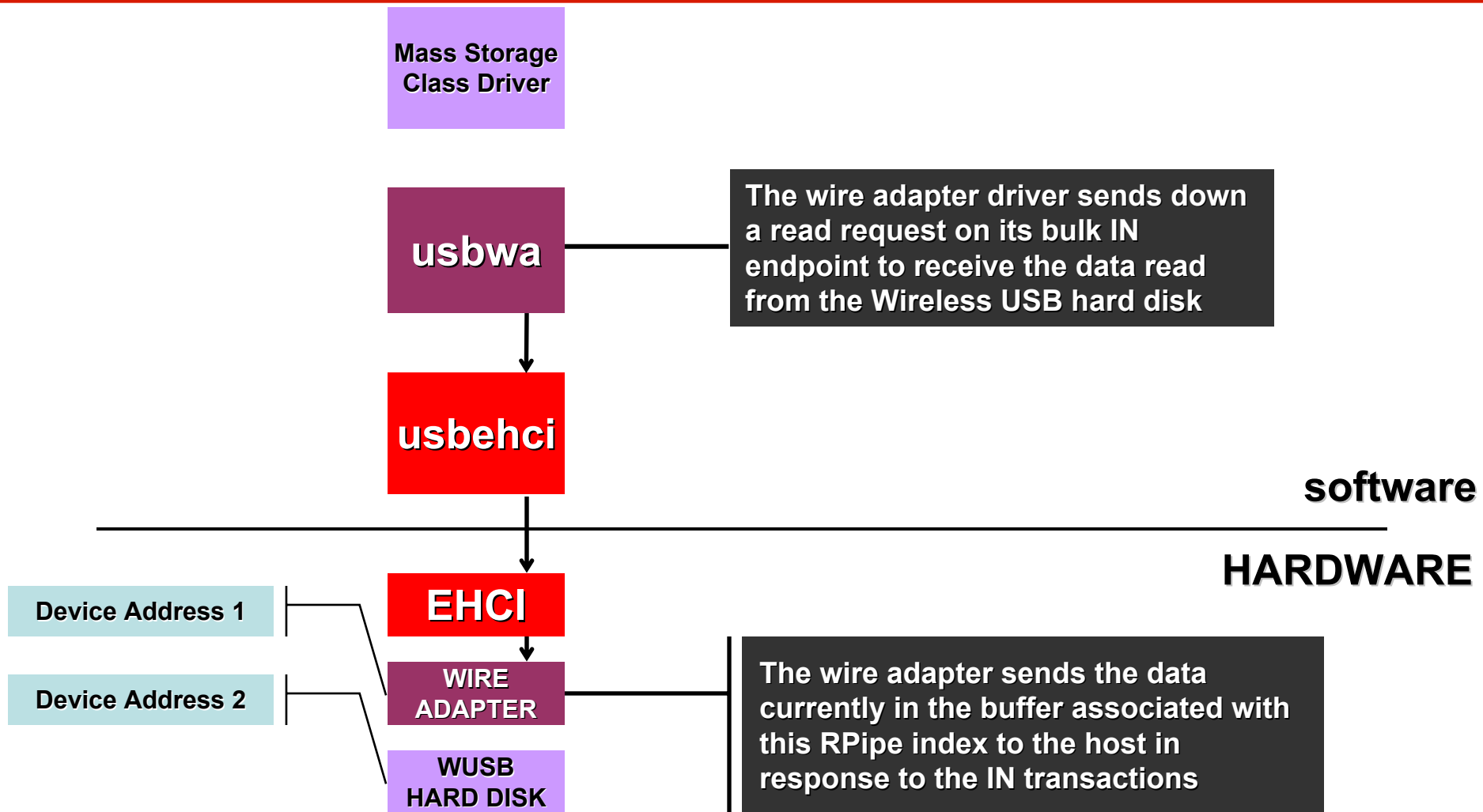

Data Flow – Request Sequence

Read Request – Completion

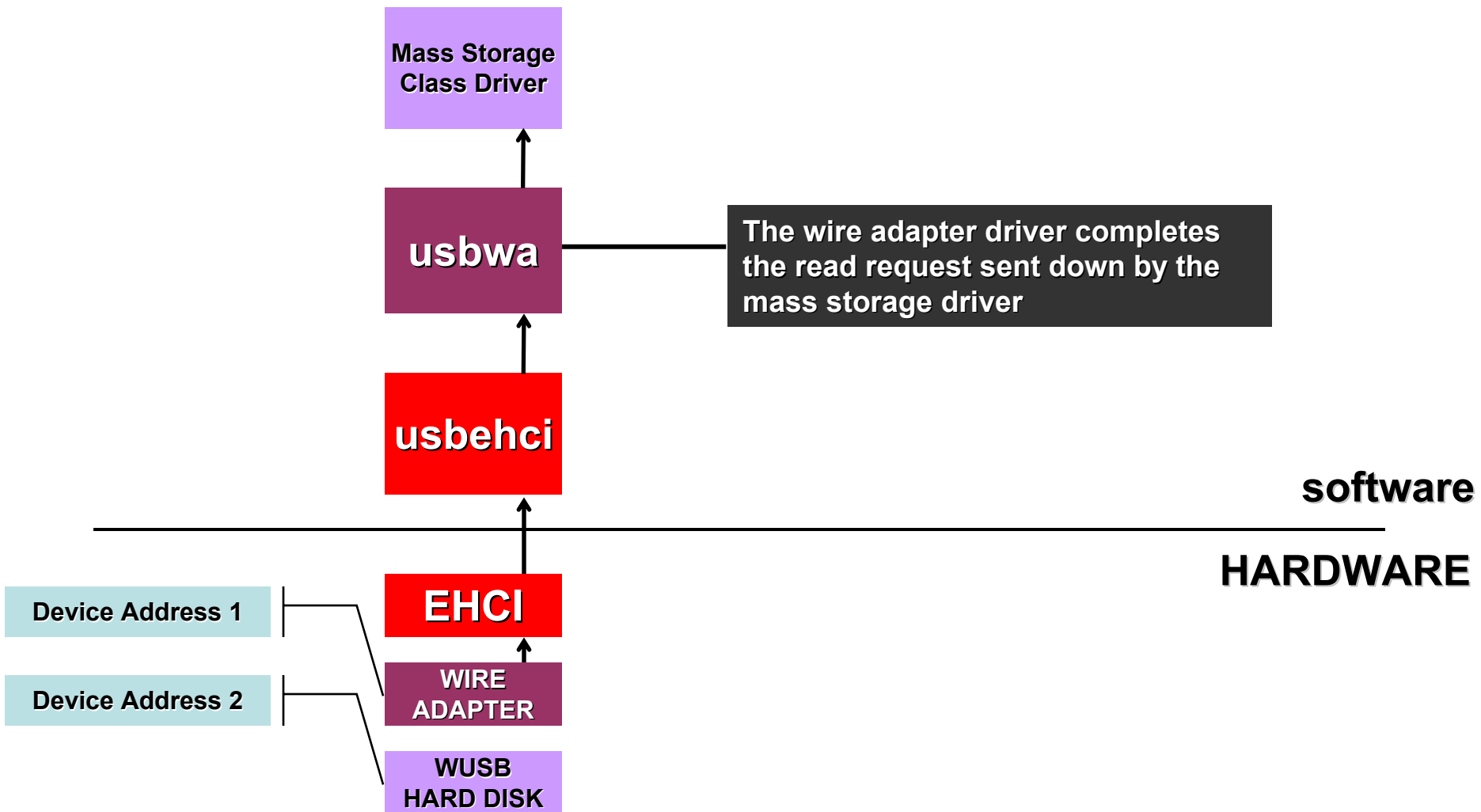

DWA Isochronous OUT Example

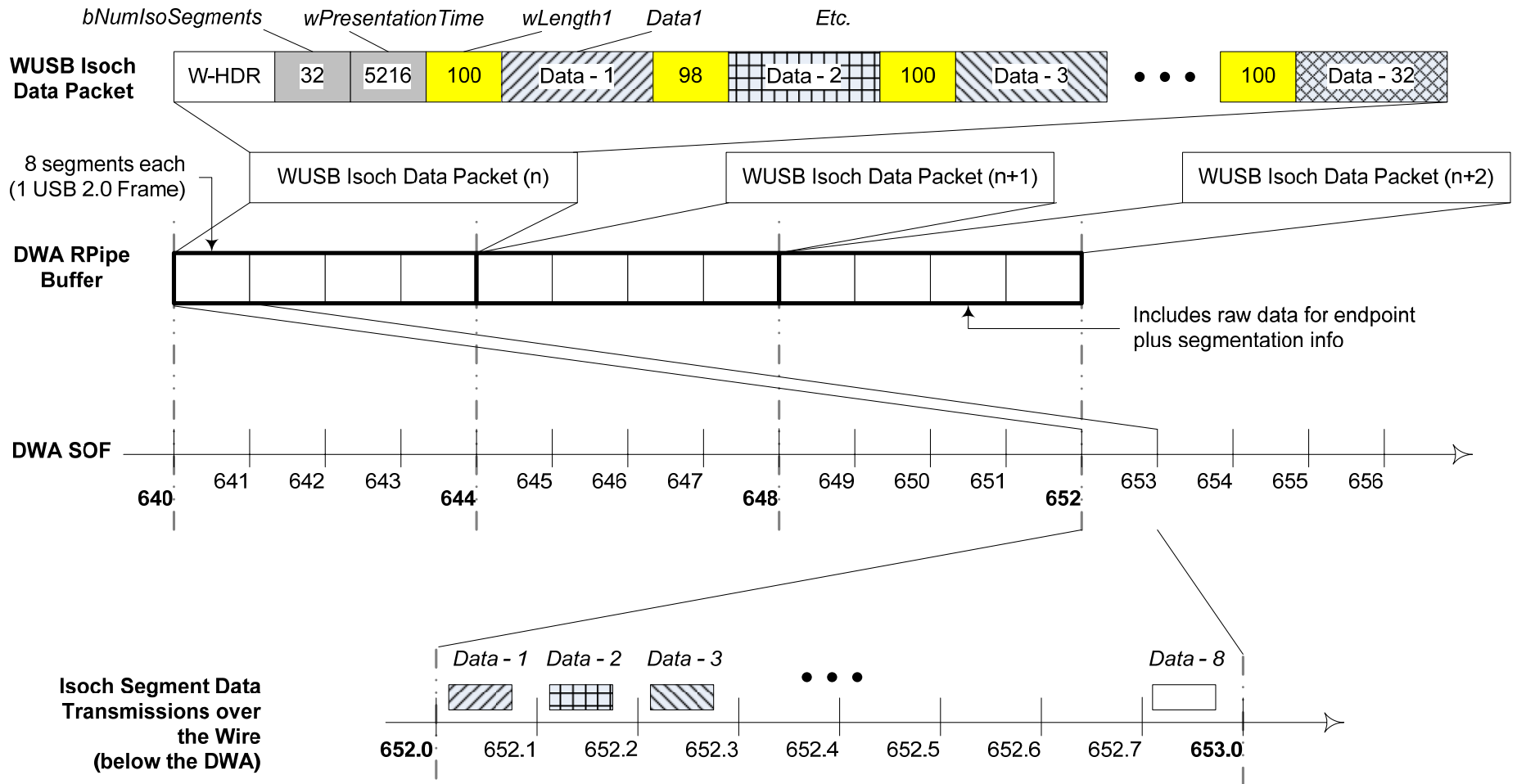

Device Manager

Example Topology Report

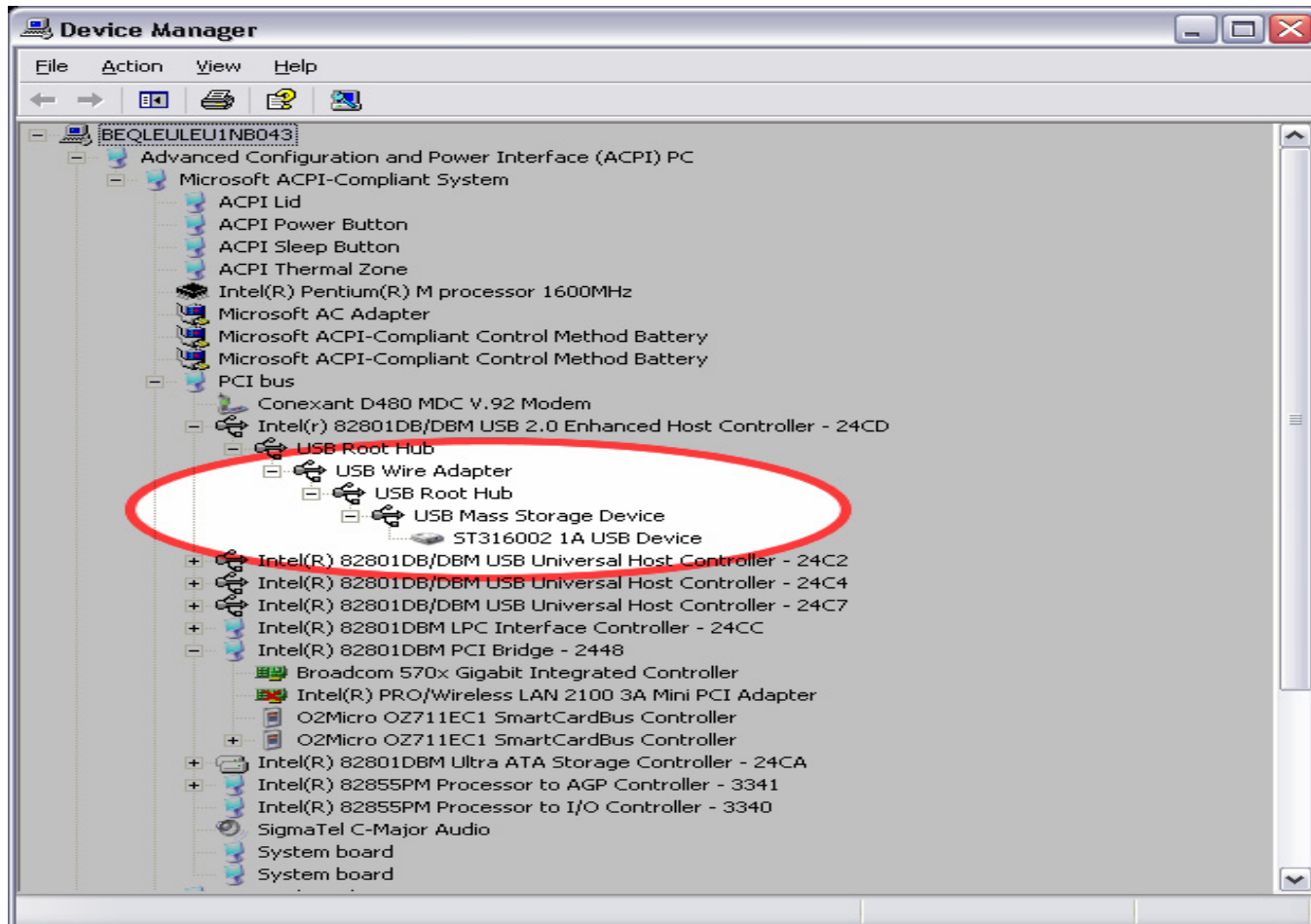

Remote Pipe State Diagram

